



# TECHNICAL UNIVERSITY OF MOMBASA

Faculty of Engineering and Technology  
DEPARTMENT OF MECHANICAL & AUTOMOTIVE ENGINEERING

## UNIVERSITY EXAMINATION 2013/2014

FIFTH YEAR SECOND SEMESTER UNIVERSITY EXAMINATION FOR  
THE DEGREE OF BACHELOR OF SCIENCE IN MECHANICAL ENGINEERING

### **EMG 2519 : MAINTENANCE ENGINEERING AND INDUSTRIAL SAFETY**

TIME: 2 HOURS

SERIES: DECEMBER, 2013

#### INSTRUCTIONS TO CANDIDATES

1. You are required to have the following for these examinations:
  - Drawing Instruments
  - Scientific Calculator
2. This paper has **FIVE** Questions.
3. Answer Question **ONE** is **COMPULSORY** and any other **TWO** Questions.
4. All relevant tables and formulae have been provided on the question paper.
5. All symbols have their usual meaning.
6. This paper consists of **SEVEN Printed pages**.

---

#### QUESTION 1 (Compulsory)

- (a) Using the table given below, indicate using an (X) which type of extinguisher is suitable for the given class of fire. Leave the box blank where the combination of class fire and extinguisher do not match.

Type of extinguisher fire	Water	Foam	Vapourizing Liquid	Co <sub>2</sub>	Dry Powder
Class B fire					

Class C fire					
Class E fire					
Class F fire					

- (b) (i) Identify the **TWO** key elements of fire protection. **(4 marks)**
- (ii) Describe the **THREE** key aspects considered in the designing of horizontal escape routes and exits. **(6 marks)**
- (iii) Describe Type A and Type D fires. **(4 marks)**
- (c) Explain the concept of compartmentalization of spaces in aiding fire control. **(2 marks)**

## QUESTION 2

- (a) Highlight various ways in which industrial accidents can be prevented. **(4 marks)**
- (b) The OSHA act sets out some requirements on fittings and attachments to boilers. Describe **FOUR** such mandatory attachments that should be affixed to boilers and steam receivers. **(4 marks)**
- (c) Describe the **FOUR** requirements on Ergonomics at the workplace, as defined by the OSHA act. **(4 marks)**
- (d) A three-storey university block has just been constructed, but its use not yet determined. Authorities are considering making it a laboratory block with chemistry, Physic and Biology labs occupying two floors, and engineering labs occupying one floor. The last floor is to be used for storage.
- (i) Analyze **FIVE** safety critical aspects of this building. **(5 marks)**
- (ii) Propose how the floors should be distributed amongst the four lab categories, and justify your answer. **(2 marks)**

## QUESTION 3

- (a) FMEA and FMECA utilize categories and levels of failure to show the criticality of a given malfunction.
- (i) Describe the **FOUR** failure categories used in FMECA. **(4 marks)**
- (ii) What are failure levels used for? **(2 marks)**
- (b) A requirement exists for an engine fuel pump to be required or replaced within 3 hours, 90% of the time. If the repair distribution is lognormal with  $S = 0.45$ :
- (i) Determine the MTTR such that the 3 hour goal is achieved. **(3 marks)**
- (ii) Determine the corresponding mode. **(2 marks)**
- (iii) If the repair distribution was exponential with the same mean, determine the percentage time in which the repair will be completed in 3 hours. **(2 marks)**
- (c) The probability density function for the time to failure for a vehicle drive train is given by:  $f(t) = 0.2e^{-t}$ ;  $0 \leq t \leq 10 \text{ years}$
- (i) If the bus undergoes preventive maintenance every 12 month. That restores it to as good as new condition; determine its reliability at the end of an 18 month warranty period. **(4 marks)**
- (ii) Compute the MTTF under the preventive maintenance plan in part (i) above. **(3 marks)**
- Q.4 (a) (i) Define TPM and state its main aim in maintenance. **(2 marks)**
- (ii) Highlight the two categories of system functions used in developing maintenance programs under the RCM policy. **(2 marks)**
- (b) For the Figure Q4(b) below:  
 $P_r(A) = P_r(B) = 0.95$ ,  $P_r(C) = P_r(D) = P_r(E) = 0.75$ .

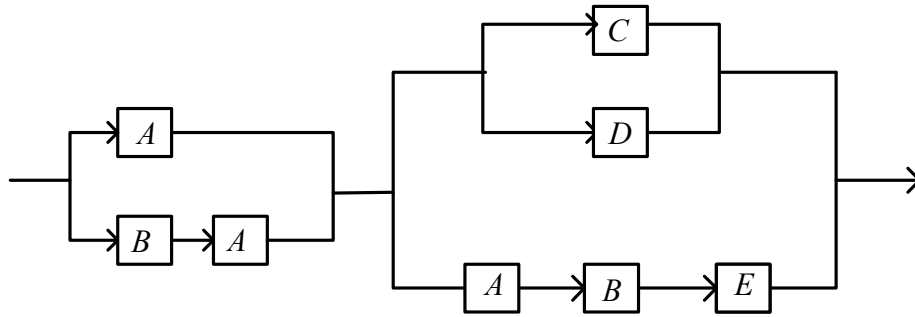

**Fig. Q4(b)**

- (i) Construct a fault tree, such that the top event is a system failure, and component failures are basic events. **(6 marks)**
- (ii) Construct a critical path fault tree that captures the most critical events that will lead to system failure. **(3 marks)**
- (iii) Compute the probability of the top event using the critical path fault tree. **(3 marks)**
- (iv) Using exactly the same components on Figure Q4(b), redesign the system so that maximum reliability can be achieved. **(4 marks)**

Q.5 (a) Describe how the shape parameter influenced the behavior of a Weibull distribution. **(4 marks)**

(b) A car engine has four belts, each showing the identical wear-out effect with a weibull shape parameter of 1.34. However, the scale parameters are 2,800, 3,400, 8,000 and 6, 100 operating hours.

- (i) If the automobile is new, determine the probability of a belt failure on a 72 hour trip. **(4 marks)**
- (ii) If the car (with the belts) has had 4000 hours of use, what is the probability of failure during the next 72 hours? **(4 marks)**

(iii) Would a burn-in period of 100 hours improve on the reliability? show this. (2 marks)

(c) Allocate a system reliability goal of 0.95 to the components of the reliability block diagram of Figure Q2 below. Assume an equal allocation to each redundant subset. Each redundant subset contains identical components.

(6 marks)

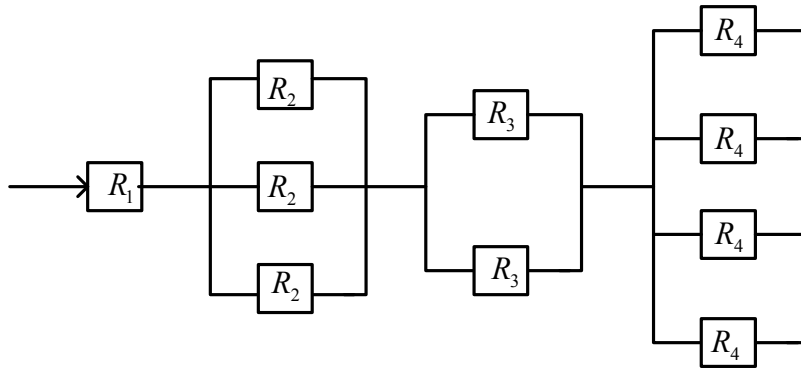

Fig. Q2(c)