



TECHNICAL UNIVERSITY OF MOMBASA

SCHOOL OF ENGINEERING AND TECHNOLOGY
DEPARTMENT OF BUILDING & CIVIL ENGINEERING
UNIVERSITY EXAMINATION FOR:

BACHELOR OF SCIENCE IN CIVIL ENGINEERING

ECV 4505: THEORY OF STRUCTURES V
SPECIAL/SUPPLEMENTARY EXAMINATION

SERIES: JULY 2025

TIME: 2 HOURS

Instructions to Candidates

You should have the following for this examination

-Answer Booklet, calculator, examination pass and student ID

This paper consists of **five** questions.

Attempt question ONE (Compulsory) and any other TWO questions.

Do not write on the question paper.

QUESTION ONE (COMPULSORY) 30 Marks

- (i) Find the load factor at collapse for the prismatic beam shown in Figure Q(i) if $M_p = 86\text{kNm}$. **(15 Marks)**

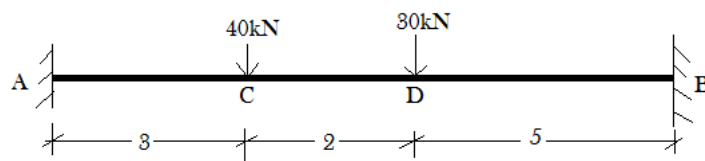

Figure Q1(i)

- (ii) Calculate the plastic section modulus, shape factor and plastic moment of the I-beam section shown in figure Q1(ii). **(15 Marks)**

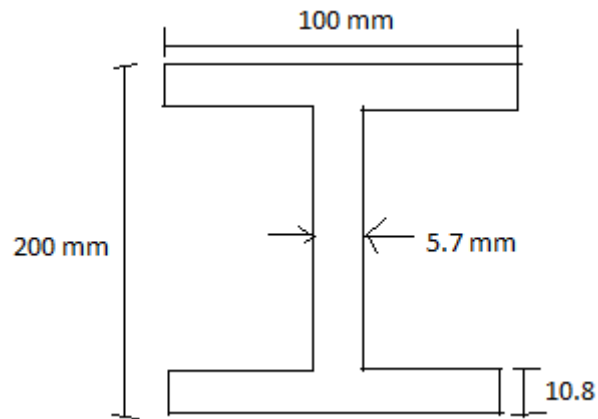

Figure Q1(ii)

QUESTION TWO

The rigid-jointed frame shown in figure Q2 is loaded with working loads as shown. Find the value of the collapse load factor when $M_p = 120\text{kNm}$. (20 Marks)

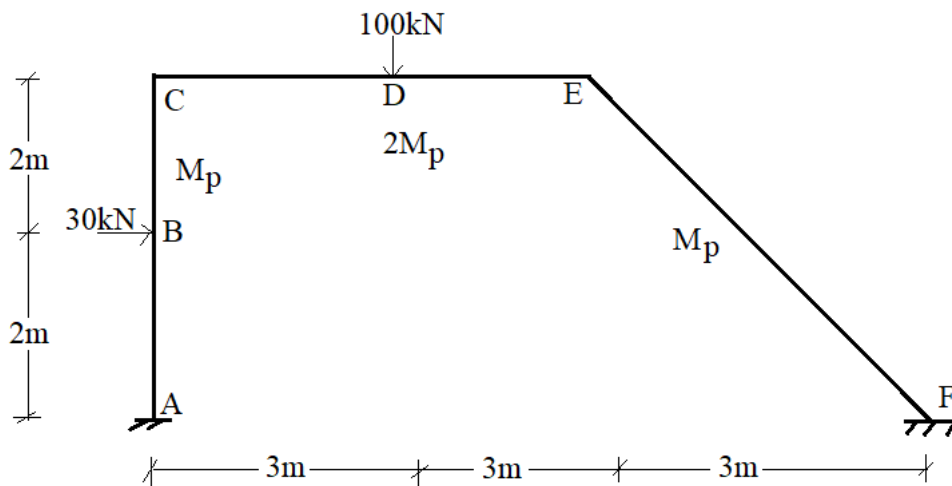

Figure Q2

QUESTION THREE

- i. List five guidelines that are followed in predicting the position of yield lines and their axes of rotation in slabs. (5 Marks)
- ii. List six fundamental assumptions made when designing linear, elastic plates with small deflections. (6 Marks)
- iii. With aid of diagrams discuss three elementary mechanisms that can occur in plastic analysis of frames. (9 Marks)

QUESTION FOUR

- (i) One of the spans of a continuous one-way slab has been so reinforced that the ultimate moment capacities at the left end, right end and in the span are 1400, 1200 and 900 kg.m/m respectively. The centre to centre distance of supports is 3m and the beam is uniformly loaded. Compute the collapse load of the slab and determine the position of the yield line. **(11 Marks)**
- (ii) Each member of the frame shown below is uniform and has a plastic moment of 25kNm. Find the collapse load factor considering the kinematic theorem. **(9 marks)**

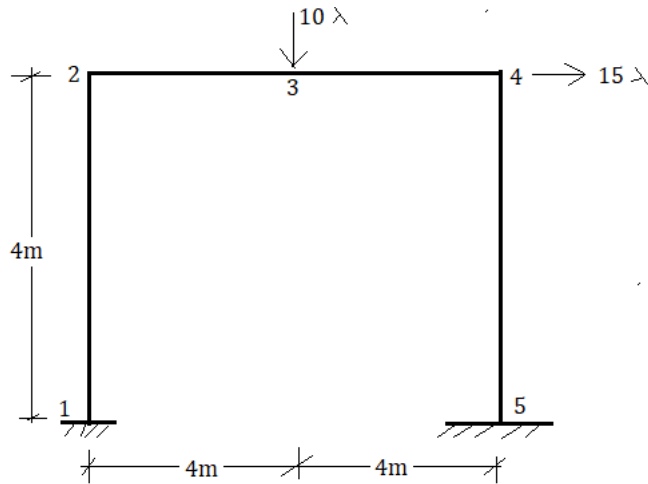

QUESTION FIVE

- (a) Determine the shape factor for the I-section section in Fig. 5(a). **(11 Marks)**

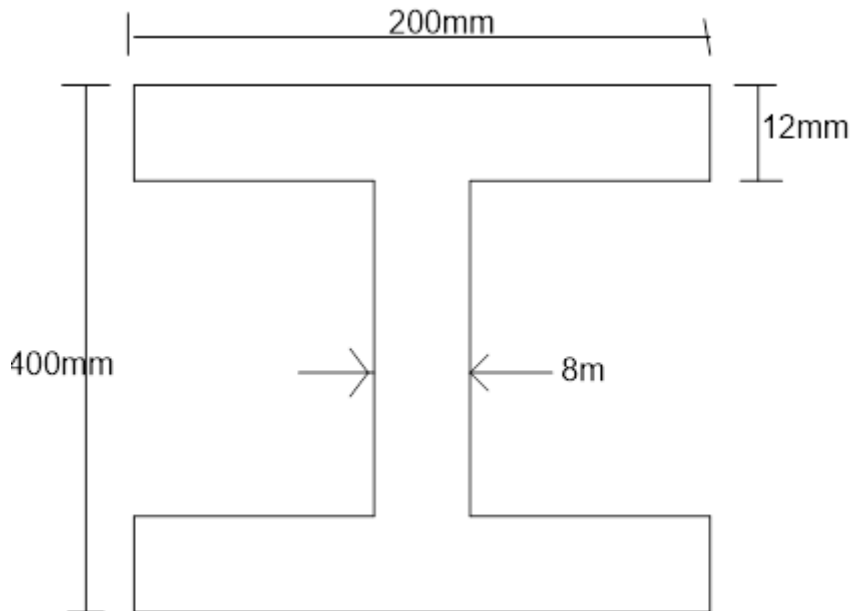

Figure 5(a)

- (iii) Briefly explain the following theorems of plastic analysis of structures
- a) Kinematic theorem

- b) The lower bound theorem
- c) Uniqueness theorem

(9 Marks)