



TECHNICAL UNIVERSITY OF MOMBASA

---

DEPARTMENT OF BUILDING AND CIVIL ENGINEERING

UNIVERSITY EXAMINATIONS FOR:

THE DEGREE OF BACHELOR OF SCIENCE/TECHNOLOGY IN CIVIL  
ENGINEERING

(Y3S2)/(Y2S2)

**ECV 4325/ TCV 4227: SOIL MECHANICS II**

SPECIAL/SUPPLEMENTARY EXAMINATION

**SERIES: MARCH 2025**

**TIME: 2 HOURS**

**INSTRUCTIONS TO THE CANDIDATE:**

1. You should have the following for this examination:
    - **Answer booklet.**
    - **Mathematical Table/Pocket Calculator.**
  2. This paper consists of **FOUR** questions.
  3. Answer question **ONE (Compulsory)** and any other **TWO** questions.
  4. This paper consists of **FIVE** printed pages.
  5. **Do not write on the question paper.**
- 

**Question One: Stresses in soils:**

(a) Define:

- (i) Principal plane,
- (ii) Principal stress.

**(2 marks)**

(b)

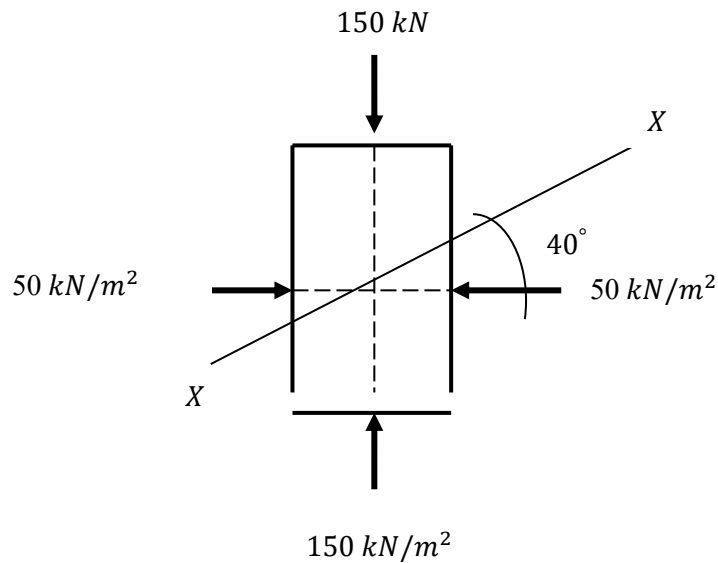

**Fig. 1.1:** Applied principal stresses

Given stresses as shown in Fig.1.1, graphically or by calculation, determine the stresses on plane  $X - X$

**(8 marks)**

(c) A cohesionless soil is subjected to a minor principal stress of  $400 \text{ kN/m}^2$ . If the angle of internal friction of the soil is  $25^\circ$ , determine:

- (i) the inclination of the plane of failure  $\theta$  to the major principal plane,
- (ii) the inclination of the maximum shear stress plane to the major principal stress,
- (iii) the normal and shear stresses on the failure plane,
- (iv) the maximum shear stress induced in the soil.

**(20 marks)**

**Question Two: Direct shear test**

- (a) State the advantages and disadvantages of the shear box test in determining the soil shear strength parameters
- (b) A shear box test carried out on a soil sample gave the data presented in Table 2.1.

**Table 2.1:** Results of shear box tests:

Test no.	Normal stress (kN/m <sup>2</sup> )	Shear stress (kN/m <sup>2</sup> )
1	200	139
2	300	180
3	400	222

For the soil tested, determine:

- (i) Cohesion,
- (ii) Angle of internal friction,
- (iii) The resultant stress on the shear plane for test No. 2

**(10 marks)**

(c) On a plane within a saturated soil mass:

- (i) *total normal stress*  $\sigma_n = 295 \text{ kN/m}^2$
- (ii) *pore water pressure*  $U = 120 \text{ kN/m}^2$
- (iii) *effective shear stress parameters:*  $c' = 12 \text{ kN/m}^2$  and  $\phi' = 30^\circ$

Calculate the effective shear stress.

**(6 marks)**

### Question Three: Triaxial test

A series of undisturbed samples from clay was subjected to consolidated undrained triaxial tests.

Results were:

**Table 3.1: Results of triaxial tests**

Test No	Cell pressure (kN/m <sup>2</sup> )	Deviator stress q (kN/m <sup>2</sup> )	Pore water pressure U (kN/m <sup>2</sup> )
1	200	650	50
2	400	770	200
3	600	880	350

Determine the shear strength parameters with respect to effective stresses.

**(20 marks)**

### Question Four: Site investigation & Soil stabilization

(a) State and explain any five information items of a site investigation report.

**(10 marks)**

(b) Discuss soil sampling under the following sub-headings:

- (i) Sample types,
- (ii) Sample spacing in a borehole.

**(4 marks)**

(c) Briefly, explain the following methods of soil stabilization:

- 1 Cement stabilization
- 2 Lime stabilization

**(6 marks)**