



**TECHNICAL UNIVERSITY OF MOMBASA**  
FACULTY OF ENGINEERING AND TECHNOLOGY  
DEPARTMENT OF BUILDING AND CIVIL ENGINEERING  
**UNIVERSITY EXAMINATION FOR:**

BACHELOR OF TECHNOLOGY IN CIVIL ENGINEERING  
**TCV 4311 : ANALYSIS OF STRUCTURES III**  
SPECIAL/SUPPLEMENTARY EXAMINATION  
**SERIES: JULY 2025**  
**TIME: 2 HOURS**

**Instructions to Candidates**

You should have the following for this examination

*-Answer Booklet, examination pass and student ID*

This paper consists of five questions.

Attempt question ONE (Compulsory) and any other TWO questions.

**Do not write on the question paper.**

**QUESTION ONE (COMPULSORY) 20 marks**

- a) Discuss the general methodology followed in analysis of structures using the Matrix Stiffness Method

**(5 Marks)**

- b) Consider a spring system shown in **Figure Q1b** below. The applied force at node 3 is 1500N while the applied forces at nodes 2 and 4 are zero. Calculate the nodal displacements and element internal forces, given that;

$$k_1 = 20\text{N/mm}, k_2 = 50\text{N/mm}, k_3 = 40\text{ N/mm}, F_{3x} = 1500\text{ N}$$

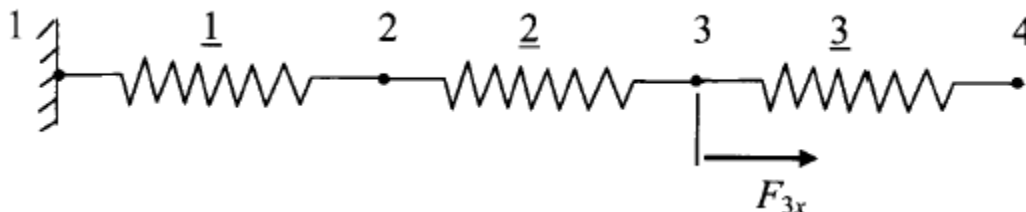

**Figure Q1b: Three Spring System**

**(15 Marks)**

### QUESTION TWO (20 Marks)

Obtain the nodal displacements, reaction forces and element internal forces of the two-bar truss structure loaded as shown in **Figure Q2** below. For each element,  $A = 1.5 \text{ in}^2$  and  $E = 20 \times 10^6 \text{ psi}$

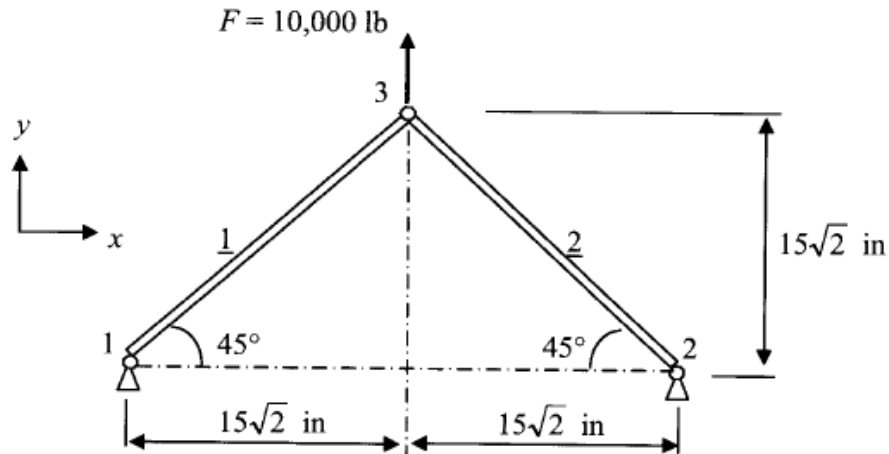

Figure Q2: Two bar truss structure

(20 Marks)

### QUESTION THREE (20 Marks)

**Figure Q3** shows a combined bar-beam structure. Element 1 is a beam and element 2 is a bar. Obtain the nodal displacements, reaction forces and element internal forces of the structure. Given that;  $E = 210 \text{ Gpa}$ , Bar:  $A = 1\text{E-}3 \text{ m}^2$ , Beam:  $A = 2\text{E-}3 \text{ m}^2$ ,  $I = 5\text{E-}5 \text{ m}^4$

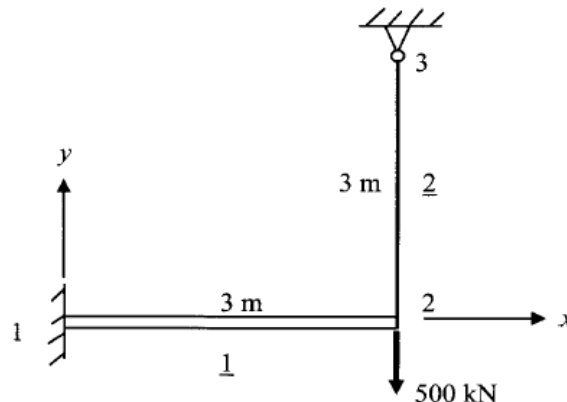

Figure Q3: A combined bar-beam structure

(20 Marks)

**QUESTION FOUR (20 Marks)**

a) Derive the Element stiffness equation for a bar element.

(5 Marks)

b) Consider a bar structure shown in Figure Q4b below. The applied forces at nodes 2 and 3 are 10000 lb at each node. Calculate the nodal displacements, reaction forces and element internal forces, given that  $A = 2.5 \text{ in}^2$  and  $E = 20 \times 10^6 \text{ psi}$  for all members.

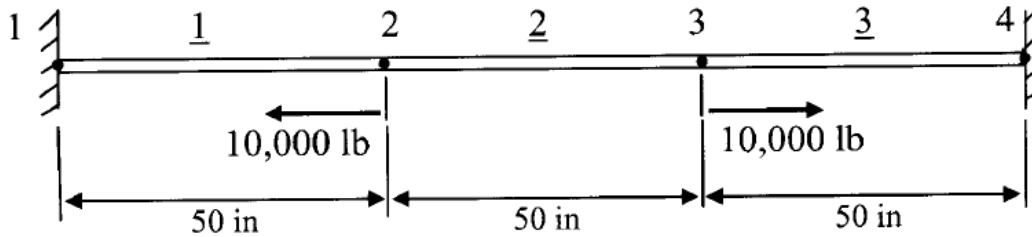

Figure Q4b: Three element bar structure

(15 Marks)

**QUESTION FIVE (20 Marks)**

Obtain the nodal displacements and reaction forces of the two-member frame structure loaded as shown in figure Q5. Find also the internal forces of element 1. For each member,  $E = 20 \times 10^6 \text{ psi}$ ,  $I = 250 \text{ in}^4$ , and  $A = 25 \text{ in}^2$

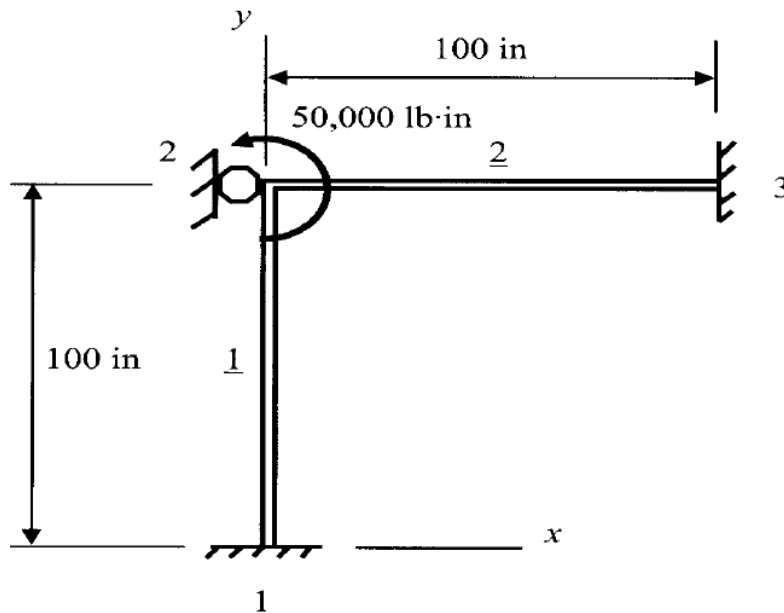

Figure Q5: Two-member frame structure

Given that Element Stiffness matrix [k] for a frame in global coordinates is;

$$[k] = (E/L)$$

$$\times \begin{bmatrix} AC^2 + \frac{12I}{L^2}S^2 & \left(A - \frac{12I}{L^2}\right)CS & \frac{-6I}{L}S & -\left(AC^2 + \frac{12I}{L^2}S^2\right) & -\left(A - \frac{12I}{L^2}\right)CS & \frac{-6I}{L}S \\ & AS^2 + \frac{12I}{L^2}C^2 & \frac{6I}{L}C & -\left(A - \frac{12I}{L^2}\right)CS & -\left(AS^2 + \frac{12I}{L^2}C^2\right) & \frac{6I}{L}C \\ & & 4I & \frac{6I}{L}S & \frac{-6I}{L}C & 2I \\ & & & AC^2 + \frac{12I}{L^2}S^2 & \left(A - \frac{12I}{L^2}\right)CS & \frac{6I}{L}S \\ & \text{Symmetry} & & & AS^2 + \frac{12I}{L^2}C^2 & \frac{-6I}{L}C \\ & & & & & 4I \end{bmatrix}$$

