



TECHNICAL UNIVERSITY OF MOMBASA

Faculty of Engineering and Technology
Department of Mechanical & Automotive Engineering
UNIVERSITY EXAMINATION FOR:
BSc. Mechanical Engineering
EMG 2418 : Pneumatics and Electro-Hydraulics
SPECIAL/SUPPLEMENTARY EXAMINATION
SERIES: SEPTEMBER 2018
TIME: 2 HOURS
DATE: Pick Date Sep 2018

Instruction to Candidates:

You should have the following for this examination

- *Answer booklet*
- *Non-Programmable scientific calculator*

This paper consists of **FIVE** questions. Attempt any **THREE** questions.

Maximum marks for each part of a question are as shown.

Do not write on the question paper.

Question ONE

- a. Derive an expression for the *bulk modulus*, B of compressed air as a function of the *applied pressure*, p and the *polytropic constant*, n . Define any other variable used.

(5 marks)

b. Name the components A-E and processes I-V in the circuit diagram below of a simple pneumatic system.

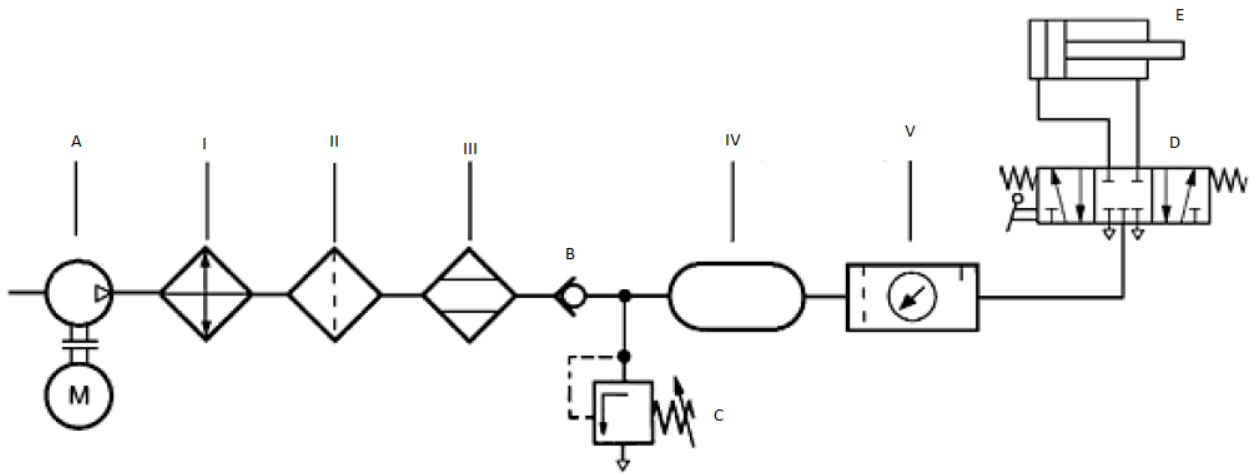

	Components
A	
B	
C	
D	
E	

	Process
I	
II	
III	
IV	
V	

(5 marks)

c. State and discuss briefly the advantages and disadvantages of pneumatic systems.

(10 marks)

Question TWO

- a. Briefly describe the following control valves, their functions and sketch the respective symbols;
- Relief Valves,
 - Directional control valves (DCVs)
 - Shuttle valves
 - Flow control valves (FCVs)

(10 marks)

- b. The figure below represents a direct-operated relief valve of the guided spool type.
- Names parts 1-5
 - Deduce the relation between the valve flow rate, Q and system pressure, P . Define all the variables used.

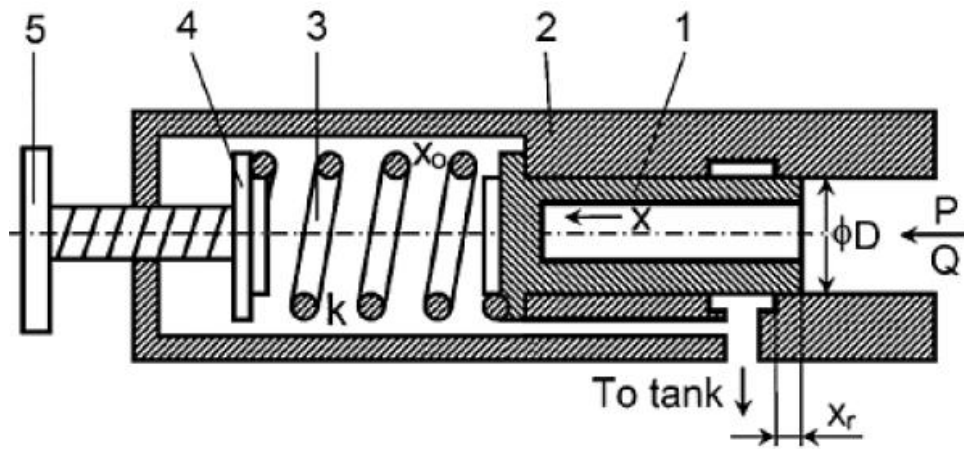

(10 marks)

Question THREE

- a. What size of accumulator is necessary to supply 4917 cm³ of fluid into a hydraulic system of maximum operating pressure of 207 bar that drops to minimum 103.5 bar? Assuming a nitrogen gas pre-charge of accumulator to be 67 bar, obtain both isothermal and adiabatic solutions.

(10 marks)

- b. A gear pump of 12.5 cm^3 geometric volume operated at 1800 rev/min delivers the oil at 16 MPa pressure. The inlet pressure is 200 kPa. Assuming an ideal pump, calculate;
- i. Pump flow rate, Q_t ,
 - ii. Driving torque, T_t ,
 - iii. Increase in the oil power, ΔN ,
 - iv. Hydraulic power at the pump exit line, N_{out} .

(10 marks)

Question FOUR

- a. Draw a maintenance schedule that outlines TWO tasks each carried out on pneumatics systems during the following periods:
- i. Operator tasks (to be carried out during the operation of plant the plant)
 - ii. Periodic maintenance (weekly or monthly)
 - iii. Quarterly or semiannually
 - iv. Annually

(8 marks)

- b. For each of the following failure symptoms in compressed air systems, state TWO most likely causes and their respective remedies.

Failure Symptom	Possible cause	Remedy
Unusual compressor noise		
Excessive pressure drop through filter		
Regulator cannot reach high set point		

(12 marks)

Question FIVE

The speed of a hydraulic cylinder is controlled by means of a series pressure compensated flow control valve, as shown in the given circuit.

Given:

Pump:	
	$V_g = 25 \text{ cm}^3/\text{rev}$
	$n = 1000 \text{ rpm}$
	$\eta_v = 0.95$
	$\eta_m = 0.93$
	$\eta_h = 1$
Directional control valve:	
	$Q = 6 \times 10^7 \sqrt{\Delta P}$
Relief valve:	
	Cracking pressure = 6 MPa
	Override pressure = 0
Hydraulic cylinder:	
	$f = 2000 \text{ Ns/m}$
	$v = 0.1 \text{ m/s}$
	$F = 9000 \text{ N}$
	Piston diameter = 60 mm
	Rod diameter = 25 mm
	No inner leakage
Calculate:	
	$P_1, P_2, P_3, P_P, Q_1, Q_2,$

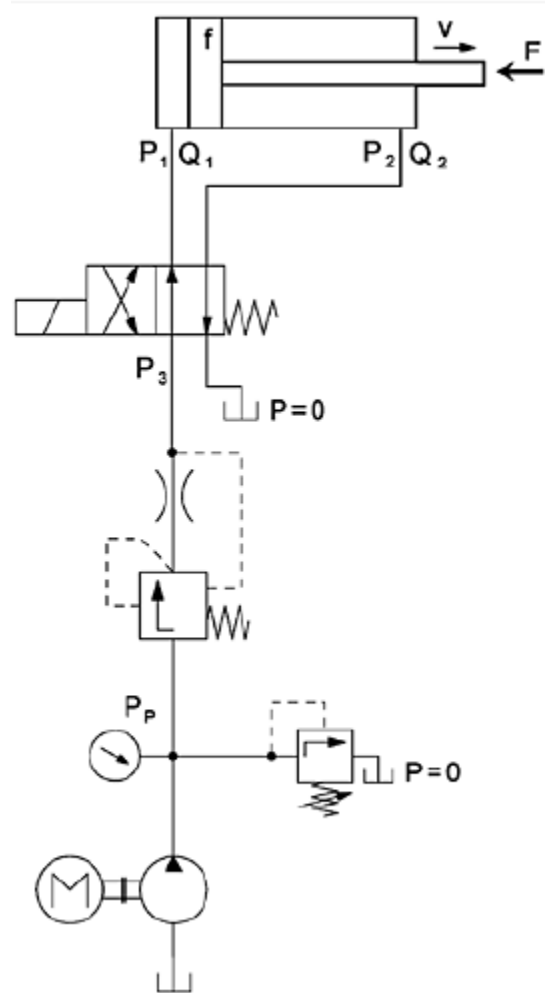

(20 marks)