



TECHNICAL UNIVERSITY OF MOMBASA

SCHOOL OF HUMANITIES AND SOCIAL SCIENCES
DEPARTMENT OF COMMUNICATION STUDIES

UNIVERSITY EXAMINATION FOR:
DIPLOMA IN GRAPHIC DESIGN
HGD 2103: ILLUSTRATION
END OF SEMESTER EXAMINATION
SERIES: DECEMBER 2016

TIME: 2 HOURS

DATE: Pick Date Dec 2016

Instructions to Candidates

You should have the following for this examination

-Answer Booklet, examination pass and student ID

This paper consists of **FIVE** questions. Attempt question ONE (Compulsory) and any other TWO questions.

Do not write on the question paper.

Question One

- a. Define the following terms
 - i. Visual (2 marks)
 - ii. Abstract design (2 marks)
 - iii. Object symbol (2 marks)
 - iv. Observational drawing (2 marks)
 - v. Perspective drawing (2 marks)

- b.
 - i) Differentiate between value and tone. (5 marks)
 - ii) Using a pencil shade the following sketched object, with given light source. (5 marks)

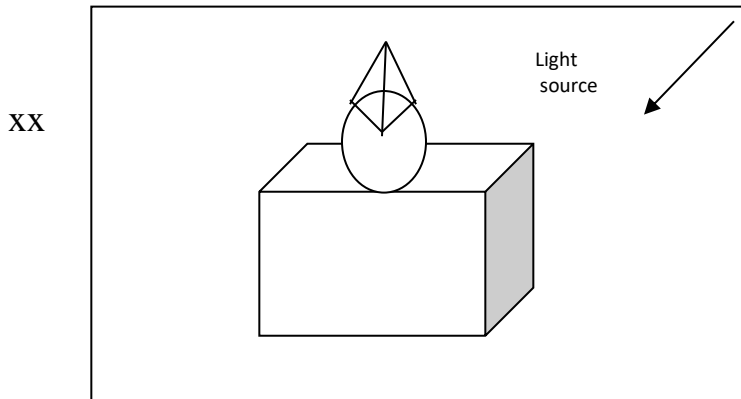

iii) Still drawing is the most suitable training ground for amateur artists.

Explain this statement briefly.

(5 marks)

iv) Distinguish between shade and tint of a colour.

(5 marks)

Question Two

Briefly describe the form elements used in various drawings of an artist.

(20 marks)

Question Three

With the help of distinguish between realistic and stylistic drawings.

(20 marks)

Question Four

Drawing moving objects provides a challenge even to professional artistes and non-seasoned artistes. Show how they handle this challenge.

(20 marks)

Question Four

Technical drawings must adhere to certain artist's principles and yet pass relevant information to the intended audience. Discuss.

(20 marks)



TECHNICAL UNIVERSITY OF MOMBASA

SCHOOL OF HUMANITIES AND SOCIAL SCIENCES
DEPARTMENT OF COMMUNICATION STUDIES

UNIVERSITY EXAMINATION FOR:

DIPLOMA IN GRAPHIC DESIGN

HGD 2109: ILLUSTRATION

END OF SEMESTER EXAMINATION

SERIES:

TIME: 2 HOURS

DATE: Pick Date Dec 2016

Instructions to Candidates

You should have the following for this examination

-Answer Booklet, examination pass and student ID

This paper consists of **FIVE** questions. Attempt question ONE (Compulsory) and any other TWO questions.

Do not write on the question paper.

B

Question One

a) Define the following terms

- i. Cartoonic drawing (2 marks)
- ii. Stylistic drawing (2 marks)

- iii. Natural drawing (2 marks)
- iv. Value (2 marks)
- v. Tints (2 marks)

b) i. Distinguish between abstract drawing and observational drawing (5 marks)

c) Shade the engineering object below with one source of light. (5 marks)

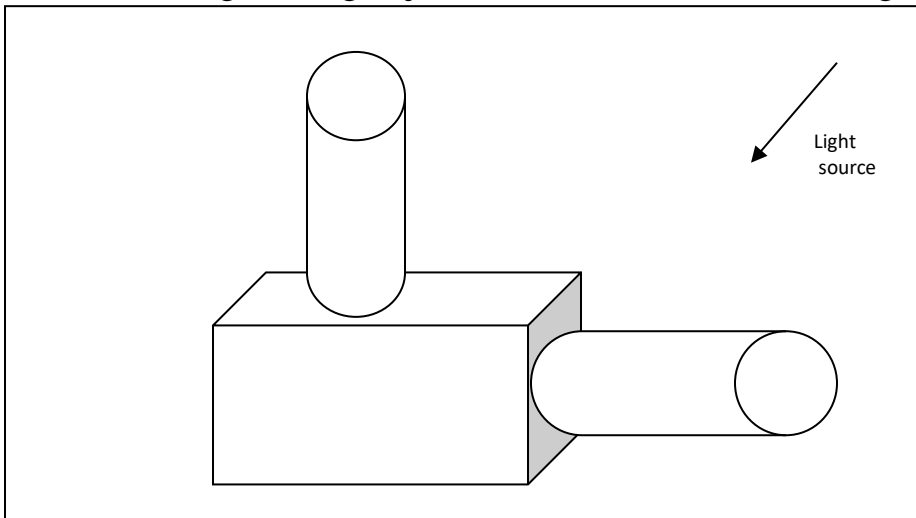

d) A designer thinks while sketching to document his ideas. Explain this principle of keeping inspirational artists motivations. (5 marks)

e) Using a diagram distinguish between neutral colour tones and value. (5 marks)

Question Two

Explain the elements of art. (20 marks)

Question Three

Caricature removes some realistic elements yet preserves the main distinctive features of an object. Explain this and illustrate with a natural object drawing (20 marks)

Question Four

Show how illustrations are better than photos in technical details. (20 marks)

Question Five

Objects are drawn to illustrate stories in publications. Discuss the need to use line work as opposed to photograph. (20 marks)