



TECHNICAL UNIVERSITY OF MOMBASA

FACULTY OF ENGINEERING AND TECHNOLOGY

DEPARTMENT BUILDING AND CIVIL ENGINEERING

UNIVERSITY EXAMINATION FOR:

BSC IN CIVIL ENGINEERING

ECE 2317: THEORY OF STRUCTURES IV

END OF SEMESTER EXAMINATION

SERIES: APRIL 2016

TIME: 2 HOURS

DATE: 12 May 2016

Instructions to Candidates

You should have the following for this examination

-Answer Booklet, Drawing Instruments, Scientific calculator, examination pass and student ID

This paper consists of five questions. Attempt question ONE (Compulsory) and any other TWO questions.

Question ONE (Compulsory)

a) Given the truss shown in figure 1 below find the horizontal and vertical components of the joint A the method of virtual work. All cross-sectional areas are 100mm^2 and $E = 290\text{kN/mm}^2$.
(20 marks)

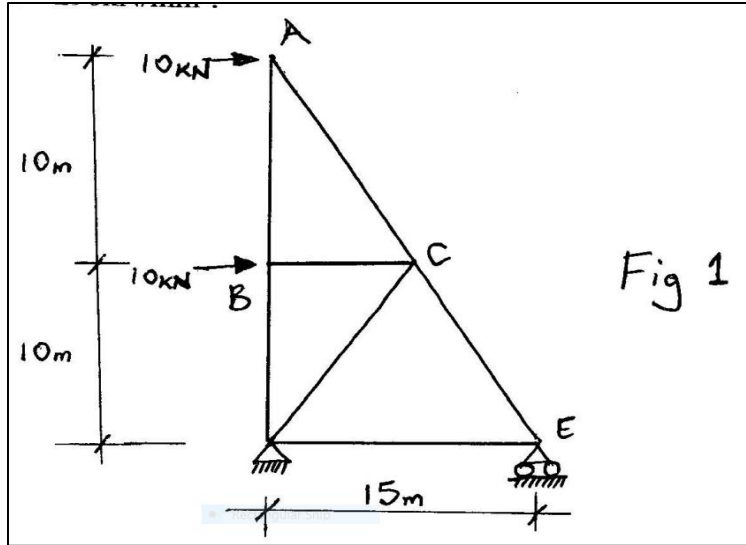

Figure 1

b) State the following

- | | |
|------------------------------------|-----------|
| (i) Principle of virtual work | (2 marks) |
| (ii) Castigliano's Second Theorem | (2 marks) |
| (iii) First Moment of Area Theorem | (2 marks) |
| (iv) Complementary Work | (2 marks) |
| (v) Second Moment of Area Theorem | (2 marks) |

Question TWO

Using the conjugate beam method, determine the slope at the point B on the beam shown in the figure 2 below.

(20 marks)

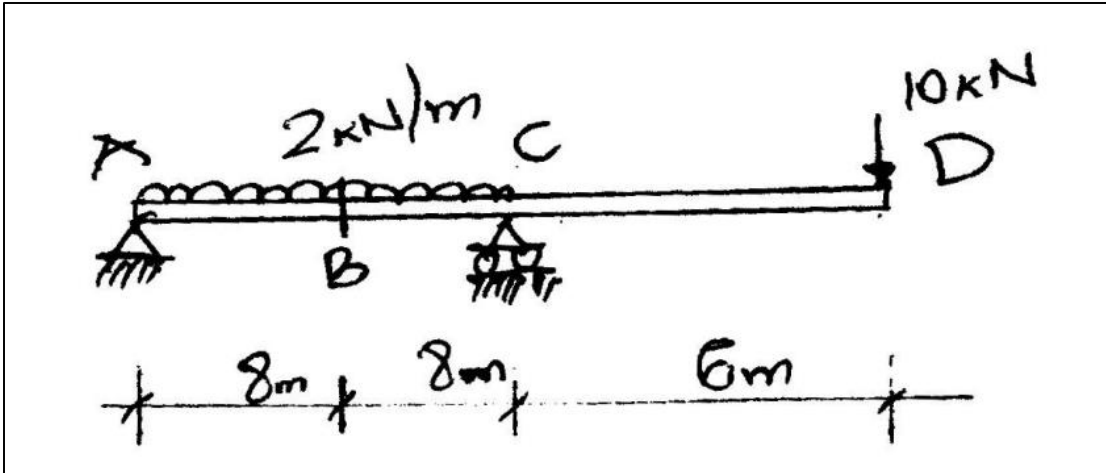

Figure 2

Question THREE

Determine the deflection at point A on the beam shown in the figure 3 below in terms of EI.

(20 marks)

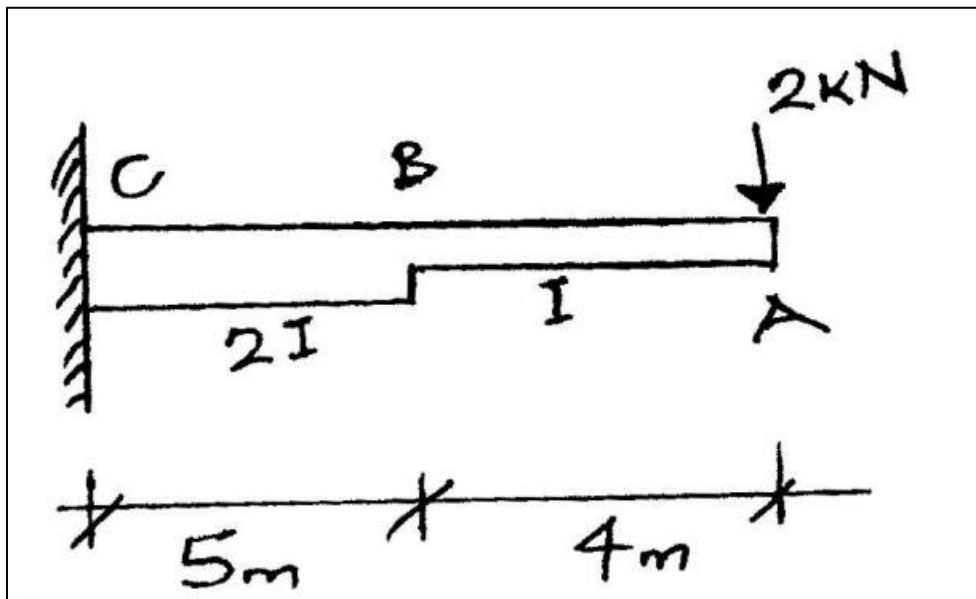

Figure 3

Question FOUR

Using Castigliano's theorem of least work, determine, the vertical displacement at point B as shown in figure 4 below. (20 marks)

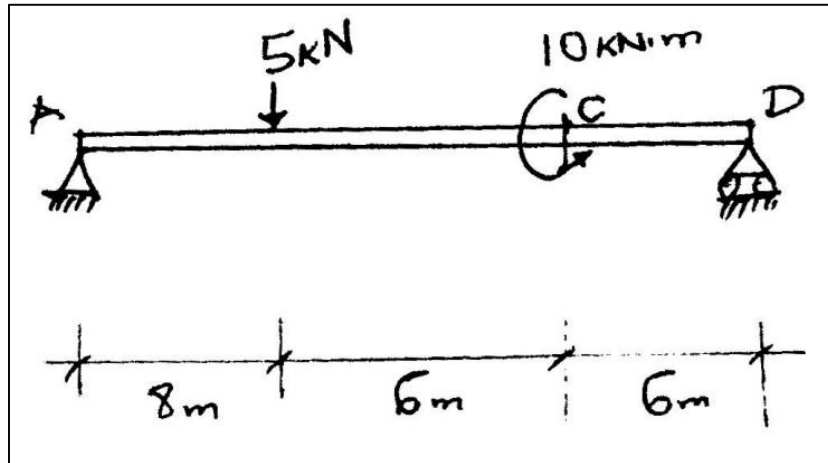

Figure 4

Question FIVE

Use the method of virtual work to determine the horizontal deflection at point C. The cross-sectional area of each member is indicated in the figure. Assume the members are simply supported and the $E=290 \text{ kN/mm}^2$.

(20 marks)

