



TECHNICAL UNIVERSITY OF MOMBASA

Faculty of Engineering and Technology
Department of Mechanical & Automotive Engineering
UNIVERSITY EXAMINATION FOR:
BSc. Mechanical Engineering
EMG 2405 : Control Engineering I
END OF SEMESTER EXAMINATION
SERIES: DECEMBER 2016
TIME: 2 HOURS
DATE: 5 Dec 2016

Instruction to Candidates:

You should have the following for this examination

- *Answer booklet*
- *Non-Programmable scientific calculator*

This paper consists of **FIVE** questions. Attempt question **ONE** and any other **TWO** questions. Maximum marks for each part of a question are as shown.

Do not write on the question paper.

Question ONE (Compulsory)

- a. Draw a block-diagram of a typical negative-feedback, closed-loop system, labelling the individual blocks and the system inputs and outputs. State two advantages and two disadvantages of closed-loop systems when compared to open-loop systems.
(5 marks)
- b. Consider a closed loop control system with a unity-feedback whose open-loop transfer function is given as,

$$G_o(s) = \frac{20}{s^2 + 5s + 5}$$

For a unit step response obtain the following,

- Undamped natural frequency, ω_n and damping ratio, ξ
- Delay time t_d
- Rise time t_r
- Peak time t_p
- Maximum overshoot M_p
- Settling time t_s (for 2%)

(14 marks)

- c. Consider the electrical circuit shown in Figure Q1(b) which consists of a capacitor in series with a resistor. R is the resistance of the resistor and C is the capacitance of the capacitor. The voltage input to the circuit is $v(t)$ whilst the potential differences across the capacitor and resistor at any time are $v_C(t)$ and $v_R(t)$ respectively.

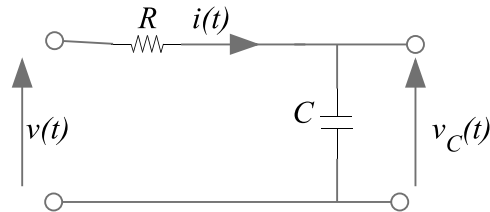

Figure Q1

- i. Derive a relationship between the output potential difference across the capacitor, $v_C(t)$, and the input voltage, $v(t)$ **(3 marks)**
- ii. Take Laplace transforms of the equation to give an expression for the relationship between, $V_C(s)$ and $V(s)$, the Laplace transforms of $v_C(t)$, and $v(t)$ respectively. Remember that the initial value of $v_C(t)$ may not be zero. **(3 marks)**
- iii. If the resistance $R = 5 \text{ k}\Omega$ and the capacitance $C = 40 \text{ }\mu\text{F}$, calculate an expression for the potential difference across the capacitor, $v_C(t)$, if there is a step input voltage applied to the system at time $t = 0$ equal to $v(t) = 240\text{V}$. Sketch the overall response of the capacitor between 0 and 0.5 seconds, assuming that the initial value of $v_C(t)$ is zero. This may be done using the trial solution or Laplace transform approach. **(5 marks)**

Question TWO

The plant manager responsible for a chemical plant is unhappy with the performance of one of the processes. When a 10°C reference input step change is applied to the process this only results in a 5°C output temperature change. The time constant of the system is 20 minutes.

- a.
 - i. Assuming that the process can be represented by a first-order model, given the above information, specify the system transfer function, $G_1(s)$, relating the output temperature to the input temperature. **(4 marks)**
 - ii. Sketch the output response of the process to the 10°C reference input step change, clearly indicating the desired steady-state value, the actual steady-state value and the relevance of the time constant. **(8 marks)**
 - iii. What is the steady-state error of the process? **(4 marks)**
- b. Initially, the manager is only concerned with the slow system response to the step change and desires that the time-constant of the system should be reduced from 20 minutes to 5 minutes. The closed-loop system control system is as shown in Figure Q2 where $G_1(s)$ is the transfer function of the process and $K(s)$ is the controller transfer function. The

manager decides to use proportional control to achieve this one design requirement. Show that the required value for the proportional controller gain to satisfy the design requirement is $K = 6$. **(4 marks)**

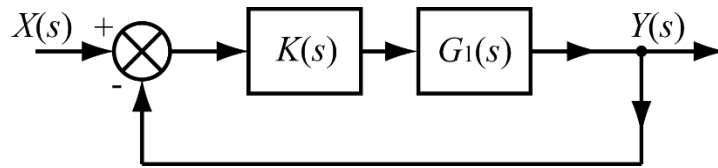

Figure Q2

Question THREE

- a. State any TWO advantages of modern control approach to system modeling as compared to classical approach. **(2 marks)**
- b. Define the following terms:
 - i. State vector,
 - ii. State variable, **(2 marks)**
- c. Consider a transfer function of a system as shown in Figure Q3c

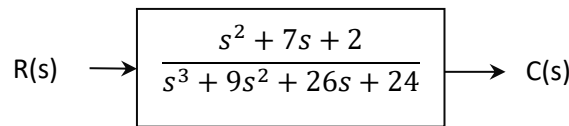

Figure Q3c

- i. Find the state equation and output equation for the phase variable representation of the transfer function.
- ii. Draw an equivalent block diagram showing phase variables. **(10 marks)**
- d. Figure Q3d shows the translational mechanical system. Obtain the state model of the system. **(6 marks)**

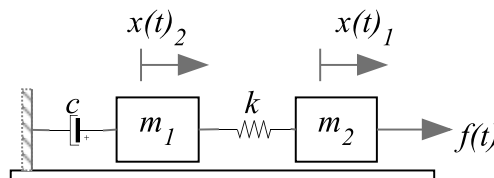

Figure Q3d

Question FOUR

- a.
- State Routh-Hurwitz criteria for stability. **(2 marks)**
 - Consider the closed loop system shown in Figure Q4a. Determine the range of values of K for which the system is stable. **(6 marks)**

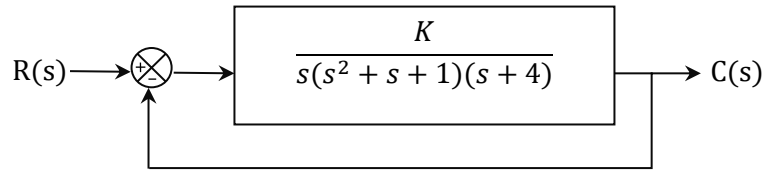

Figure Q4a

- b. Figure Q4b shows the block diagram of a complex system which includes three negative feedback loops, the outermost of which is a unity feedback loop.

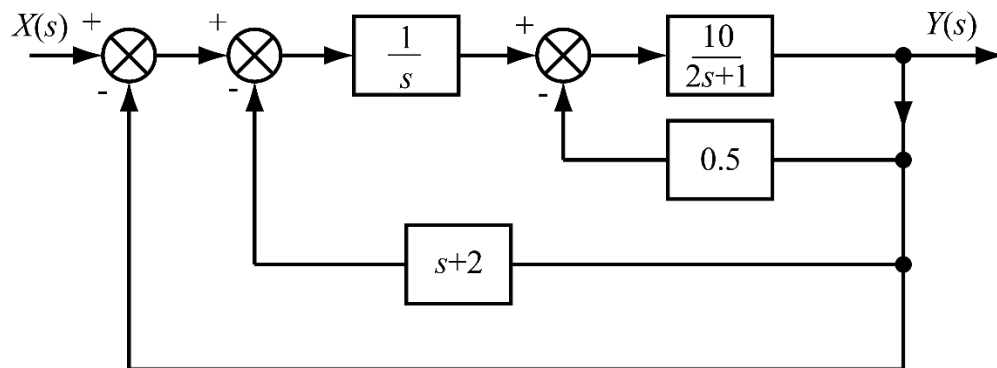

Figure Q4b

- Show whether the above closed-loop system is stable or unstable. **(6 marks)**
- Either through knowledge of the response of system types to different inputs or by applying the final value theorem calculate the steady-state error for this system to the following inputs:
 - A step input of magnitude 10.
 - A ramp input given by $x(t) = 10t$.
 - A parabolic input given by $x(t) = 10t^2$. **(6 marks)**

Question FIVE

- a. Consider a spring-mass-damper system shown in Figure 5a.
- Determine the transfer function relating the displacement $x(t)$ and input force $f(t)$ for the spring-mass-damper system.
 - Obtain the values of c , k and m . The system was initially relaxed. **(20 marks)**

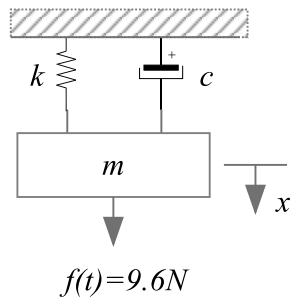

Figure 5a.

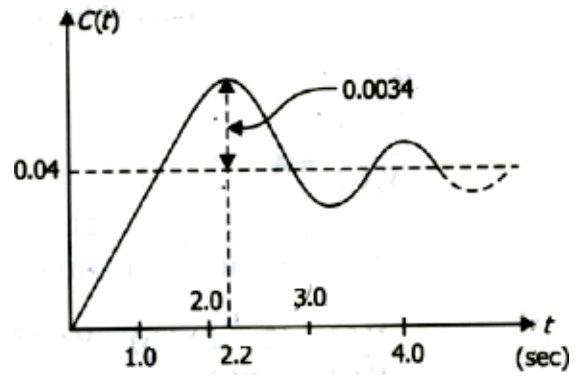

Figure 5b.