



TECHNICAL UNIVERSITY OF MOMBASA

FACULTY OF APPLIED SCIENCES MATHEMATICS AND PHYSICS DEPARTMENT UNIVERSITY EXAMINATION FOR BACHELOR OF TECHNOLOGY DEGREE IN APPLIED PHYSICS (BTAP)

EEE 4250: ANALOGUE ELECTRONICS

END OF SEMESTER EXAMINATION

SERIES: May Series 2016:

TIME: 2 HOURS

DATE: May 2016

Instructions to Candidates

You should have the following for this examination

Answer Booklet, examination pass and student ID

This paper consists of **FIVE** questions. Attempt Question **ONE** and any other **TWO** questions.

Do not write on the question paper.

Marks may be awarded for clear work showing steps followed.

1. The following **constants** and **h -parameters** may be useful:

i) Transistor **2N3904** h-parameters:

- $h_{11} = 3.5\text{k}\Omega$; $h_{12} = 1.3 \times 10^{-4}$;

ii) Transistor **2N3904** h-parameters:

- $h_{11} = 3.5\text{k}\Omega$; $h_{12} = 1.3 \times 10^{-4}$; $h_{21} = 120$; $h_{22} = 85\mu\text{S}$

iii) Conversion to CB amplifier parameter

- $h_{ib} = \frac{h_{ie}}{D}$

- $h_{eb} = \frac{h_{ie}h_{oe} - h_{re}(h_{fe})}{D}$

- $D h_{fb} = \frac{h_{fe}(1 - h_{re}) - h_{ie}h_{oe}}{D}$

- $D = (1 + h_{fe})(1 - h_{re}) + h_{ie}h_{oe}$

QUESTION ONE (30MRKS)

a) State the following theorems:

(i) Thevenin theorem.

(1mrks)

- (ii) Norton theorem . (1mrks)
- b) (i) Differentiate between a positive and negative feedbacks of a operational amplifier. (4mrks)
- c) (i) What is an oscillator? (1mrks)
(ii) List any two types of oscillators. (2mrks)
(iii) When can an amplifier act as an oscillator. (2mrks)
- d) (i) Describe a photodiode. (3mrks)
(ii) Give any three applications of diodes. (3mrks)
- e) How is a solar cell different from a photodiode? (3mrks)
- (iv) Study the hybrid model shown below. The circuit demonstrates a h-parameter analysis of a transistor network.

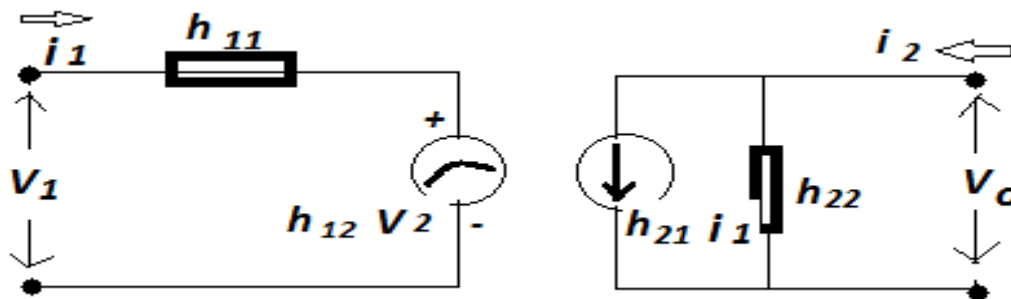

Given that

- (i) $V_1 = 35.2\text{mV}$ while $i_1 = 0.013\text{mA}$, determine h_{11} (2mrks)
- (ii) $i_2 = 1.6\text{mA}$ and $i_1 = 0.03\text{mA}$, determine h_{21} (2mrks)
- (v) What are the following power electronic devices:
- a. Diac (1mrk)
 - b. Triac (1mrk)
 - c. Thyristor (1mrk)
 - d. Silicon controlled rectifier. (1mrk)
 - e. Gate-Turn-Off switch. (1mrk)
 - f. Uni-junction transistor. (1mrk)

QUESTION TWO (20MRKS)

- a) (i) What is a thyristor? (1mrks)
(ii) Why is a thyristor also called a bistable switch? (1mrk)
(iii) How is it designed to control large currents in three lead mode? (2mrks)
(iv) Sketch a diagram to a circuit symbol of a thyristor. (3mrks)

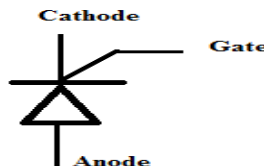

- (ii) When does a P-N junction gain an equilibrium condition? (1mrk)

(iii) Study the figure below and use it to answer the questions that follow.

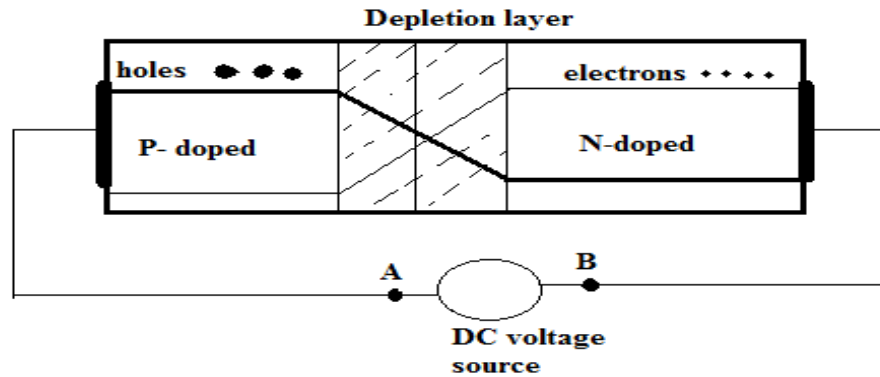

- (i) Explain what will happen to the holes and the electrons if;
- (a) Terminal A is made more positive than terminal B. (2mrks)
 - (b) Terminal B is made more positive than terminal A. (2mrks)
 - (c) Give two applications of the above circuit. (2mrks)
- a) The figure below shows a circuit of a Triac. Describe how it operates. (6 mrks)

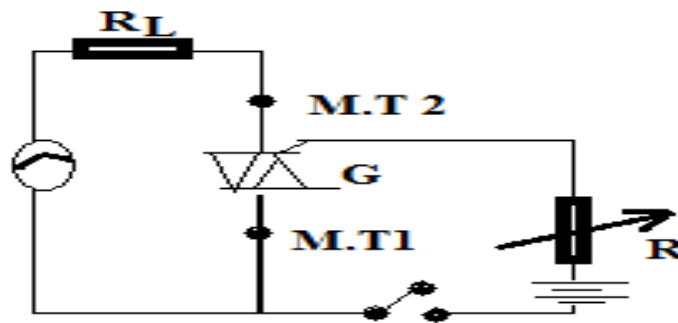

QUESTION THREE (20MRKS)

Study the loaded two port transistor network below with a load resistance r_L .

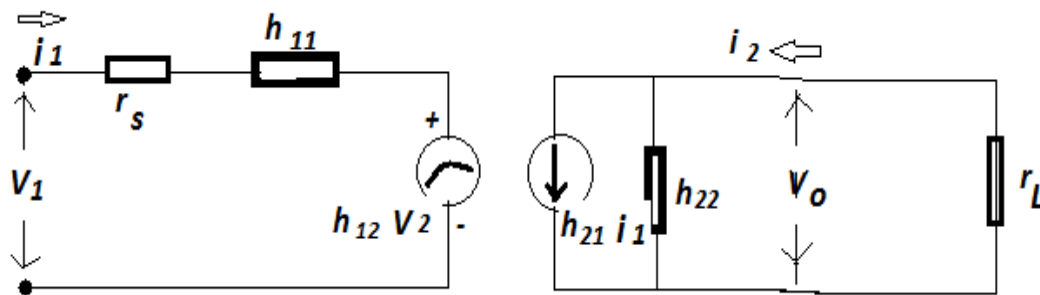

Given that the sketch is a reduced CE amplifier connection network with a quiescent current of 1mA having manufacture specifications as $h_{11} = 3.5\text{k}\Omega$; $h_{12} = 1.3 \times 10^{-4}$; $h_{21} = 120$; $h_{22} = 85\mu\text{S}$ and $r_s = 1\text{k}\Omega$.

a)(i) Derive an expression to show that the current gain, A_i of this circuit can be given by;

$$A_i = \frac{h_{21}}{h_{22}r_L} \quad (3\text{mrks})$$

- (i) If this transistor has $r_L = 3,5\Omega$, calculate its current gain, A_i (2mrks)
 b) (i) Derive an expression to show that voltage gain, A_v can be given by

$$A_v = \frac{-h_{21}r_L}{(h_{11} + (h_{11}h_{22} - h_{12}h_{21}r_L))} \quad (3mrks)$$

- (i) Calculate A_v given that $r_L = 4.6k\Omega$ for the above transistor. (2mrks)
 c) (i) Show that the input impedance Z_{in} can be given by;

$$Z_{in} = h_{11} - \frac{h_{12}h_{21}r_L}{(1 + h_{22}r_L)} \quad (3mrks)$$

- (ii) Determine Z_{in} for this two port transistor network. (2mrks)
 d) (i) Show that the output impedance for this two port network transistor can be expressed as;

$$Z_{out} = \frac{(r_s + h_{11})}{[(r_s + h_{11}) - h_{12}h_{21}]} \quad (3mrks)$$

- (ii) Determine the output impedance Z_{out} . (2mrks)

QUESTION FOUR (20MRKS)

- a) What is a diode? (2mrks)
 (i) Explain how a diode functions. (3mrks)
 (ii) Differentiate between a light emitting diode and a photodiode. (2mrks)
 (iii) What is a solar cell? (2mrk)
 (iv) Explain how a solar cell can be regarded as a diode. (3mrks)
 (v) Differentiate between a solar cell and photodiode. (2mrks)
 b) In a silicon material which has $n_i \approx 1.4 \times 10^{16} \text{ m}^{-3}$ at $T = 300 \text{ K}$ and donor and acceptor densities in **p-** and **n-**regions given as $N_a = 10^{24} \text{ m}^{-3}$, $N_d = 10^{22} \text{ m}^{-3}$, for a **p+n** junction, calculate;
 (i) the built-in voltage V_{bi} (3mrks)
 (ii) The depletion layer width if $\epsilon = 11.7 \epsilon_0$ for Si) (3mrks)

QUESTION FIVE (20MRKS)

- a) (i) What is a multistage transistor amplifier? (1mrk)
 (ii) Differentiate between a cascaded amplifier and a compound amplifier. (2mrks)
 b) Sketch a circuit showing a Resistance- Capacitance Coupled amplifier and explain the function of the capacitor in the circuit. (8 mrks)
 c) In a two stage Resistance–Capacitance amplifier, each stage has one $R_{in} = 1k\Omega$; $\beta = 100$ and $R_c = 2k\Omega$. Find
 (i) The voltage gain in the second stage. (3mrks)
 (ii) The voltage gain in the first stage. (3mrks)
 (iii) The overall gain of the amplifier in number and also in dB. (3mrks)

END