



TECHNICAL UNIVERSITY OF MOMBASA

FACULTY OF ENGINEERING AND TECHNOLOGY

DEPARTMENT OF MECHANICAL & AUTOMOTIVE ENGINEERING

UNIVERSITY EXAMINATION FOR:

DIPLOMA IN MARINE ENGINEERING

EMR 2213 : ENGINEERING DRAWING & DESIGN II

END OF SEMESTER EXAMINATION

SERIES: APRIL 2016

TIME: 3 HOURS

DATE: 15 May 2016

Instructions to Candidates

You should have the following for this examination

-Answer Booklet, examination pass and student ID, Drawing paper A2

This paper consists of **FIVE** questions. Attempt question ONE (Compulsory) and any other TWO questions.

Do not write on the question paper.

Question ONE

Figure QN 1 shows parts of a MARINE CLAMP drawn in first angle orthographic projection. Assemble the parts and draw, FULL SIZE, the following views in THIRD ANGLE projection;

- (a) a sectional front elevation along the cutting plane X-X
- (b) the end elevation in the direction of arrow P
- (c) the plan.

Include SIX leading dimensions, symbol of projection and parts list.

(30 marks)

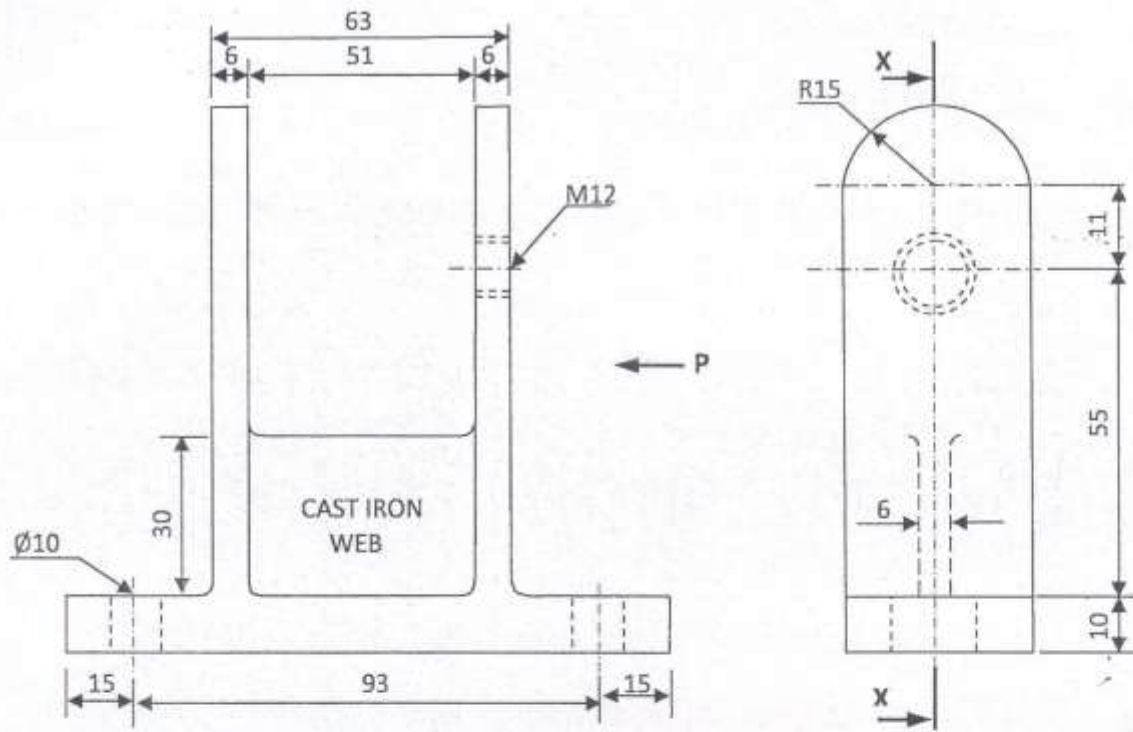

PART 1: CLAMP MAIN FRAME (CAST IRON)

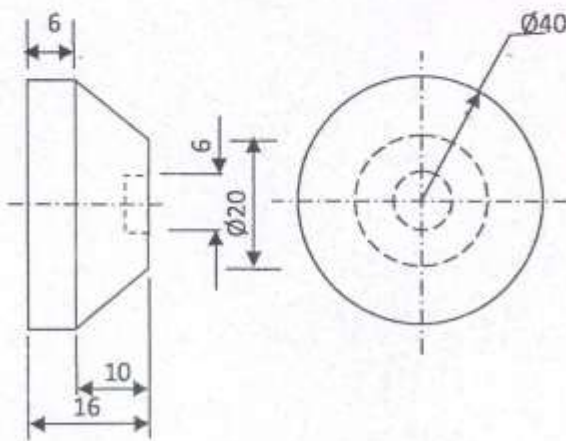

PART 3: CLAMP JAW (STEEL)

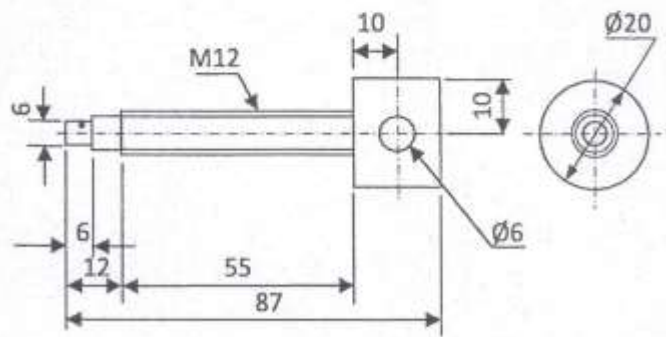

PART 2: MAIN SCREW (STEEL)

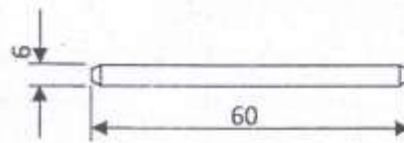

PART 4: TOMMY HANDLE BAR (STEEL)

Figure QN 1.

Question TWO

- (a) Explain the importance of correct storage of materials in the workplace. (4 marks)
- (b) State the hazard and how it can be avoided when storing the following materials;
- (i) Fluids (hydraulics)
 - (ii) Pipes
- (6 marks)
- (c) State the basic colour that pipes are painted for identification of the following content;
- (i) Air
 - (ii) Water
 - (iii) Oil
 - (iv) Electric conduit
 - (v) Steam
- (5 marks)
- (d) State at least FIVE types of valves used in pipe lines and explain the main function of each.
- (5 marks)

Question THREE

- (a) i) Define the term Ergonomics.
- ii) State the THREE groups of items that ergonomists consider in order to make the best use of human abilities.
- iii) Explain briefly the THREE groups stated in (a)ii above
- (8 marks)
- (b) i) State SIX different types of controls .
- ii) For each of the controls named in b(i) above, state its task suitability. (6 marks)
- (c) Explain briefly the following types of display;
- (i) Qualitative
 - (ii) Quantitative
 - (iii) Representational
- (6 marks)

Question FOUR

(a) Explain briefly the procedure to be followed in case of a fire outbreak. (6 marks)

(b) i) Explain briefly the following types of fire;

(I) A

(II) B

(III) C

(IV) E

ii) State the suitable types of fire extinguisher for each of the type of fire in b(i) above.

(10 marks)

(c) Explain briefly the use of the following fire extinguishing equipment;

(i) Hose reel

(ii) Fire blanket

(4 marks)

Question FIVE

(a) i) What is the use of flanges in pipework?

ii) With the aid of sketches, state and explain THREE types of flanges used in pipework.

(10 marks)

(b) Draw Isometric views of the following power transmission components;

i) Oldham coupling

ii) Disc coupling

iii) Universal coupling.

(6 marks)

(c) Draw the symbols of the following items used in pipework;

i) Reducing 90° elbow flanged

ii) 90° elbow flanged

iii) Safety valve screwed

iv) Union welded

(4 marks)