



TECHNICAL UNIVERSITY OF MOMBASA
FACULTY OF APPLIED SCIENCES
MATHEMATICS AND PHYSICS DEPARTMENT
UNIVERSITY EXAMINATION FOR BACHELOR OF TECHNOLOGY DEGREE IN
APPLIED PHYSICS (BTAP)

EEE 4250: ANALOGUE ELECTRONICS

END OF SEMESTER EXAMINATION

SERIES: May Series 2016:

TIME: 2 HOURS

DATE: May 2016

Instructions to Candidates

You should have the following for this examination

- Answer Booklet, examination pass and student ID

- This paper consists of **FIVE** questions. Attempt Question **ONE** and any other **TWO** questions.

- **Do not write on the question paper.**

- Marks may be awarded for clear work showing steps followed.

- The following **constants** and **h -parameters** may be useful:

i) Transistor **2N3904** h-parameters:

- $h_{11} = 3.5\text{k}\Omega$; $h_{11} = 1.3 \times 10^{-4}$; $h_{21} = 120$; $h_{22} = 85\mu\text{S}$

ii) Conversion to CB amplifier parameter

-
$$h_{ib} = \frac{h_{ie}}{D}$$

-
$$h_{eb} = \frac{h_{ie} h_{oe} - h_{re} (h_{fe})}{D}$$

-
$$D h_{fb} = \frac{h_{fe} (1 - h_{re}) - h_{ie} h_{oe}}{D}$$

-
$$D = (1 + h_{fe})(1 - h_{re}) + h_{ie} h_{oe}$$

QUESTION ONE (30MKS)

- a) (i) What is a P-N junction? (1mk)
(ii) Sketch a labeled diagram to show a simple P-N junction. (2mks)
(iii) Explain how to forward bias a PN junction. (2mks)
(iv) Explain how to reverse bias a PN junction. (2mks)
(v) What is a diode? (2mrks)
- b) (i) What is an operational amplifier? (1mk)
(v) An operational amplifier has a voltage gain of 500 which falls to 100 when a negative feedback is applied. Calculate the feedback fraction, m. (4mks)
- c) (i) Explain what is meant by positive feedback of an operational amplifier. (1mk)

- (ii) State four effects of positive feedback. (4mks)
- d) (i) What is an oscillator? (1mk)
- (ii) Differentiate between a damped oscillator and an undamped oscillator. (4mks)
- e) (i) Give any two h-parameters used to analyze a two port unloaded linear network of transistors. (2mks)
- (ii) Explain how the h-parameters you have given above are obtained. (4mks)

QUESTION TWO (20MKS)

- a) What happens inside the p-n Junction Diode? (4mks)
- b) Using a sketch diagram;
 - (i) Explain what happen when the diode is forward biased? (5mks)
 - (ii) Explain what happens in the Reverse biased? (5mks)
- c) (i) What is a solar cell? (2mks)
- (ii) Using a sketch diagram explain how a solar cell operates. (4mks)

QUESTION THREE (20MKS)

The circuit below is of a CB transistor amplifier. Study it and use it to answer the questions that follow. Given that the amplifier has a quiescent collector current of about 1mA, use the h-parameters for **2N3904** to determine;

- (a) A_i ; A_v ; $A_i Z_{in}$ and Z_{out} for this amplifier. (12mks)

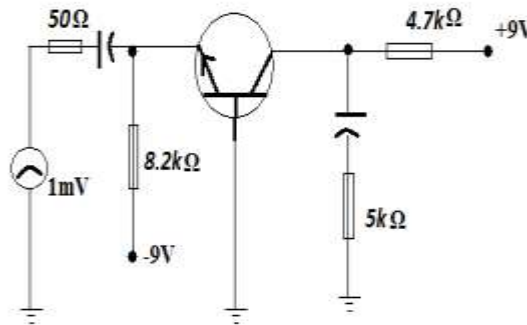

- b) If the h-parameter of the transistor were for CE configuration as follows: $h_{ie} = 1000\Omega$; $h_{re} = -3.5 \times 10^{-4}$; $h_{fe} = 55$ and $h_{oe} = 20\mu S$. Find the current gain, A_i and voltage gain, A_v if $r_L = 2k\Omega$. (8mks)

QUESTION FOUR (20MKS)

- a) (i) What is a field Effect Transistor? (2mks)
- (ii) Sketch a labeled circuit symbol of a Field Effect Transistor. (2mks)
- (iii) What is a bipolar transistor? (2mks)
- (iv) State one use of a bipolar transistor. (1mk)
- (v) Give any two types of Bipolar transistors. (2mks)
- (vi) What is a Solar cell? (1mk)
- b) Study the hybrid model shown below. The circuit demonstrates h-parameter analysis of a transistor network.

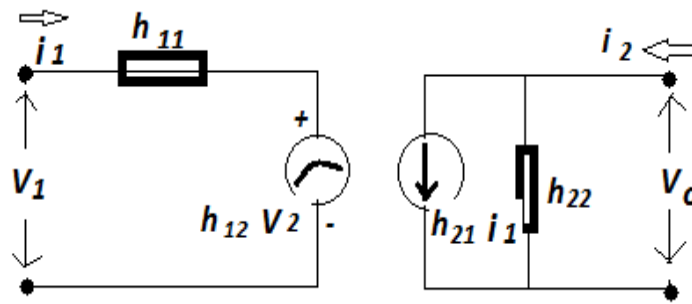

- (i) Given that, $V_1 = 35.2\text{mV}$ while $i_1 = 0.013\text{mA}$, determine h_{11} . (2mks)
- (ii) Given that, $i_2 = 1.6\text{mA}$ and $i_1 = 0.03\text{mA}$, determine h_{21} . (2mks)
- c) What are the following power electronic devices:
- Diac. (1mk)
 - Triac. (1mk)
 - Thyristor. (1mrk)
 - Silicon controlled rectifier. (1mrk)
 - Gate-Turn-Off switch. (1mk)
 - Uni-junction transistor. (1mk)

QUESTION FIVE (20MKS)

- a) (i) Differentiate between a positive and a negative feedback. (2mks)
- (ii) Give two ways in which negative feedback can be classified. (1mk)
- b) In a class A transistor operation amplifier, the Q-point is located at 200mA , 10V . When a signal is applied, the collector current swings between 440mA and 40mA while the voltage swings between 12V and 1V respectively. Find the ;
- Output AC power (3mks)
 - Output AC power (3mks)
 - Efficiency (3mks)
 - Power dissipated (2mks)
- c) A germanium transistor has a thermal resistor at its junction as 0.33°C/mW and the apparent temperature is 28°C . Calculate;
- the maximum power dissipation that can be allowed without heat sink. (3mks)
 - the maximum power that can be allowed if a heat sink is used which reduces the thermal resistance of the transistor to 0.09°C/mW . (3mks)

END