



# TECHNICAL UNIVERSITY OF MOMBASA

Faculty of Applied and Health Sciences

Department of Mathematics and Physics

## UNIVERSITY EXAMINATION FOR:

Bachelor of Technology in Applied Chemistry

APS 4103 Physics for Chemists

## END OF SEMESTER EXAMINATION

**SERIES: May 2016**

**TIME: 2 Hours**

**DATE:**

### Instructions to Candidates

You should have the following for this examination

-Answer Booklet, examination pass and student ID

This paper consists of five questions. Attempt Question One and any other two questions.

**Do not write on the question paper.**

### *Important constants*

Permittivity of free space  $\epsilon_0 = 8.85 \times 10^{-12} \text{ C}^2 \text{ N}^{-1} \text{ m}^{-2}$

Acceleration due to gravity  $g = 9.81 \text{ ms}^{-2}$

$\frac{1}{4\pi\epsilon_0} = 9 \times 10^9 \text{ Fm}^{-2}$

Electric charge  $e = 1.63 \times 10^{-19} \text{ C}$

### **Question One (30 marks)**

- List two uses and two limitations of dimensional analysis. (4 marks)
- Explain the importance of seat belts and speed governors in curbing road accident fatalities. (4 marks)
- An object of mass  $m$  lies on a smooth plane. When the plane is gradually lifted from the ground, it is observed that the object begins to slide when the angle between the plane and the ground is  $45^\circ$ . Calculate the coefficient of static friction. (2 marks)
- State coulombs law. (2 mark)
- What is meant by the term conservation of charge? (1 mark)
- The charges on three identical spheres are  $10 \mu\text{C}$ ,  $-6 \mu\text{C}$  and  $13 \mu\text{C}$ . the spheres are touched together and then separated. What are the charges on the three spheres now? (3 marks)
- List at least three dissimilarities between Coulomb force and Gravitational force. (3 marks)

- h. Two resistors  $4\ \Omega$  and  $6\ \Omega$  are connected in series. If the voltage across the  $4\ \Omega$  is  $2\ \text{V}$ , find the source voltage. (3 marks)
- i. A parallel plate capacitor of plate area  $0.1\ \text{m}^2$  and a separation of  $0.001\ \text{m}$  is charged to  $100\ \text{V}$ . Calculate the capacitance of the capacitor and the charge on each plate. (4 marks)
- j. State Kirchhoff's laws. (2 marks)
- k. Define electrical resistivity of a material and state the SI units. (2 marks)

**Question Two (20 marks)**

- a. State the laws of friction (3 marks)
- b. What is meant by the term linear momentum? (1 mark)
- c. Explain how force is related to linear momentum (1 mark)
- d. Give the mathematical expression for Newton's second law of motion and state how the Newton is defined from this law (2 marks)
- e. A large cardboard box of mass  $0.75\ \text{kg}$  is pushed across a horizontal floor by a force of  $4.5\ \text{N}$ . The motion of the box is opposed by a frictional force of  $1.5\ \text{N}$  and air resistance force  $kv^2$  where  $k = 6 \times 10^{-2}\ \text{kg/m}$  and  $v$  is the speed of the box.
  - i. find the speed of the box if the box is not accelerating (4 marks)
  - ii. calculate the force the floor is exerting on the box (2 marks)
- f. A body of mass  $10\ \text{kg}$  is pulled up a rough surface inclined at an angle of  $30^\circ$  to the horizontal by a  $60\ \text{N}$  force. If the frictional force between the plane and the body is  $20\ \text{N}$  find:
  - i. the acceleration of the body up the plane (5 marks)
  - ii. the normal reaction (2 marks)

**Question Three (20 marks)**

- a. Three charges  $q_1 = -9\ \mu\text{C}$ ,  $q_2 = 8\ \mu\text{C}$  and  $q_3 = 2\ \mu\text{C}$  are located at the corners of an equilateral triangle of sides  $0.15\ \text{m}$ . Find the net electrostatic force exerted on  $q_3$ . (5 marks)
- b. Two point charges  $q_1$  and  $q_2$  of  $8\ \text{nC}$  and  $-8\ \text{nC}$  respectively are placed  $0.1\ \text{m}$  apart as shown in Figure 1. Find the electric fields at
  - i. A (3 marks)
  - ii. B (3 marks)
  - iii. C (5 marks)

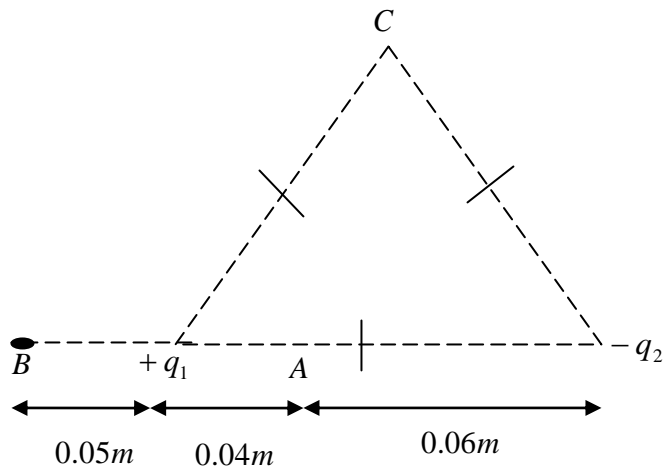
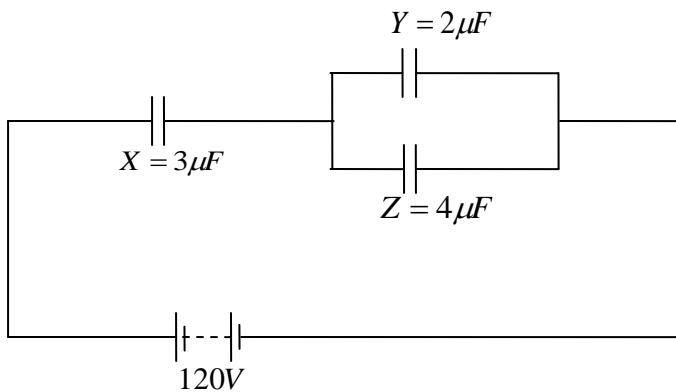

**Figure 1: Charges**

- c. Define electric potential due to a point charge. (1 mark)
- d. Two point charges  $+2 \text{ nC}$  and  $-3 \text{ nC}$  separated by a distance of  $20 \text{ cm}$ . Find the potential at a point  $P$  midway between the charges. (3 marks)

**Question Four (20 marks)**

- a. For the circuit of Figure 2 calculate the (I) charges on, and (II) the potential difference across
- X (4 marks)
  - Y (3 marks)



**Figure 2 : Capacitors**

- b. Show that the energy stored in a capacitor is  $w = \frac{1}{2} CV^2$  (4 marks)
- c. A  $5 \mu\text{F}$  capacitor is charged by a  $12 \text{ V}$  supply and is then discharged through a  $2 \text{ M}\Omega$  resistor.
- what is the charge on the capacitor at the start of the discharge? (2 marks)

- ii. what is the charge on the capacitor after 5 s (3 marks)
- iii. the current in the circuit after 5 s (4 marks)

**Question Five (20 marks)**

- a. State ohms law (1 mark)
- b. When a  $10\ \Omega$  resistor is connected across the terminals of a cell of EMF  $E$  and internal resistance  $r$ , a current of  $0.1\ \text{A}$  flows through the resistor. If the  $10\ \Omega$  resistor is replaced with a  $3\ \Omega$  resistor, the current increases to  $0.24\ \text{A}$ . Find  $E$  and  $r$ . (5 marks)
- c. In the circuit of Figure 3, find
  - i. effective resistance (3 marks)
  - ii. total current (2 mark)

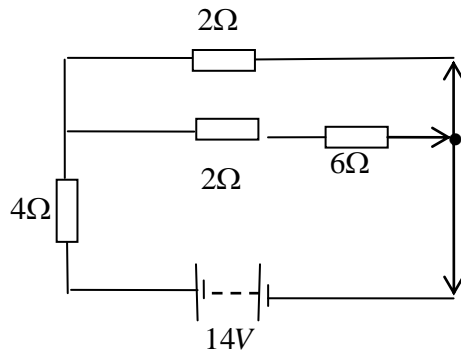

Figure 3: Resistors

- d. In Figure 4, use Kirchoff's law to find
  - i.  $I_1$  (3 marks)
  - ii.  $I_2$  (3 marks)
  - iii.  $I_3$  (3 marks)

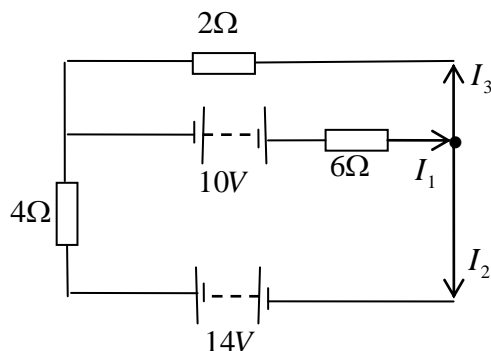

Figure 4: Resistors