



TECHNICAL UNIVERSITY OF MOMBASA

FACULTY OF APPLIED SCIENCES MATHEMATICS AND PHYSICS DEPARTMENT UNIVERSITY EXAMINATION FOR BACHELOR OF TECHNOLOGY DEGREE IN APPLIED PHYSICS (BTAP) AND BACHELOR OF TECHNOLOGY DEGREE IN RENEWABLE ENERGY (BTRE)

APS 4301: WAVE THEORY AND TIDAL ENERGY END OF SEMESTER EXAMINATION

SERIES: May Series 2016:

TIME: 2 HOURS

DATE: May 2016

Instructions to Candidates

You should have the following for this examination

Answer Booklet, examination pass and student ID

This paper consists of **FIVE** questions. Attempt Question **ONE** and any other **TWO** questions.

Do not write on the question paper.

The following constraints may be useful.

Gravitation acceleration, $g = 9.89 \text{ m/s}^2$

QUESTION ONE (30 MRKS)

1. a) (i) What is the difference between a 'beat' and 'resonance'? (2mrks)
(ii). Give one significance of Fourier analysis on waves. (1mrk)
(iii) List two factors affect the amplitude of a deep sea water wave? (2mrks)
(iv) Calculate the tidal energy of wave in sea water with a density of 1.25 kgM^{-3} having an amplitude of $1.12 \times 10^{-4} \text{ km}$ as it progress in the sea. (3mrks)
- b) A torsion pendulum with a torsion constant, $k = 0.0025\text{N/m}$ and moment of inertia, I was designed such that it can use a ring, disc and sphere of the same mass of 0.0021g and radius of 0.6 m . If a disc was used and displaced to the horizontal with uniform rotation, derive an expression to show that its period T , can be given by; $T = 2\pi\sqrt{\frac{I}{k}}$ (4mrks)
- (i) What will be its period if a disc is used ($I = \frac{1}{2} MR^2$)? (2mrks)
(ii) What will be its period if a disc is used ($I = MR^2$)? (2mrks)
(iii) What will be its period if a disc is used ($I = \frac{3}{5} MR^2$)? (2mrks)
(iv) Comment on the values of (ii); (iii); (iv) above. (2mrks)

c). Two identical particles of similar mass of M were connected by a spring of constant k_{12} . Each particle was then connected to fixed points with two other springs of constant, k_1 and k_2 as shown in figure 1 below and the particles were restricted to move only along the x -axis with two degrees of freedom x_1 and x_2 from equilibrium position respectively.

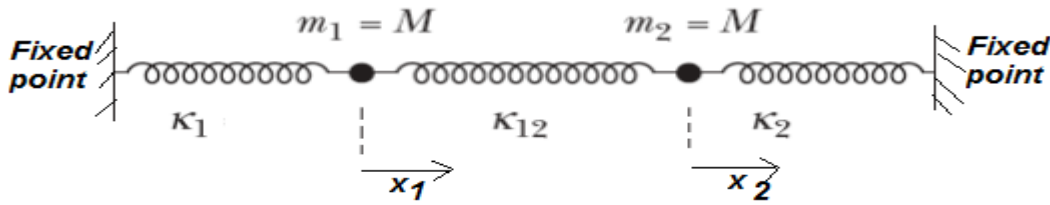

Figure 1: A system of three springs and two similar masses

(i) Show that when $k_1 = k_2 = k$, the characteristic frequencies of the system can be given as;

$$\omega_1 = \sqrt{\frac{k + 2k_{12}}{M}} \quad \text{and} \quad \omega_2 = \sqrt{\frac{k}{M}} \quad (10\text{mks})$$

QUESTION TWO (20 MRKS)

a) (i) Give one difference between a free vibration and a decaying vibration. (2mrks)

(ii) Define the term transient as used in forced harmonic oscillation. (1mrks)

b) A spring with a weak spring constant, k , of length $l = 0.05\text{m}$ is loaded with a small mass, $M = 0.03\text{kg}$ and displaced through an angle of 0.08° to execute simple harmonic motion. Derive an expression to;

(i) show that its period, T , can be given by; $T = 2\pi\sqrt{\frac{m}{k}}$ (5mks)

(ii) show that its instantaneous velocity can be expressed as; $v = \sqrt{\frac{k}{m}}(A^2 - x^2)$ (5mrks)

(iii) Find the periodic time for this spring. (2mrks)

c) A spring was attached to a mass, M and allowed to execute simple harmonic motion on a frictionless table as shown in figure 2 with displacement, x varying as $x = A \cos(\omega t + \phi)$. Given that at the initial time, $t = 0$, the displacement of the block M was at $x = x_0$ having a velocity of $v = v_0$.

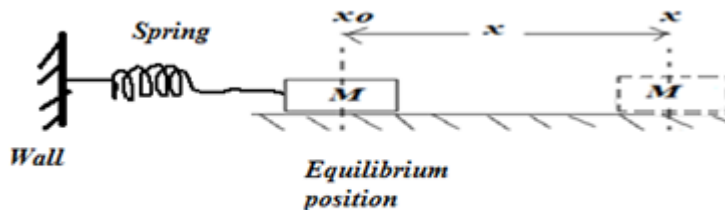

Figure: 2

Derive an expression for the amplitude, A . (5mrks)

QUESTION THREE (20 MRKS)

a) (i) Define the term Wave power. (1mrk)

(ii) State the Fourier Theorem for transformation of waves. (3mrks)

(iii) Give one implication of Fourier transformation on waves. (2mrks)

- (iv) Differentiate between Kinetic energy and potential energy of a wave. (2mrk)
- b) A spring was set in the TUM science Lab to execute a free simple harmonic motion but a sinusoidal force given by $F = F_o \sin \omega t$ was added to the spring.

- (i) Derive an expression to show that the resulting superposed oscillation can be expressed as;

$$\frac{\partial^2 x}{\partial t^2} + \omega_o^2 x - \frac{F_o}{m} \cos \omega t = 0 \text{ where } \omega_o \text{ is the frequency of the spring. (3mrks)}$$

- (ii) If this force introduced a damping term ‘ bv ’ into the spring, show that the resulting amplitude can be given as $A = \frac{F_o}{m\sqrt{\omega_o^2 - \omega^2} - (\gamma\omega^2)}$ where $\gamma = \frac{b}{m}$ and $\omega^2 = \frac{k}{m}$ of added force. (5mrks)

- c) A simple pendulum with a bob of mass, M and length l was displaced a small angle, θ , from the equilibrium to execute simple harmonic motion, show that the periodic time, T can be expressed as;

$$T = 2\pi \sqrt{\frac{\ell}{g}} \quad (4mrks)$$

QUESTION FOUR (20 MKS)

- a) (i) Differentiate between a vibration and a wave. (2mrks)
 (ii) Give two examples of waves. (2mrks)
 (iii) Differentiate between free vibration and damped vibration. (4mrks)
- b) Figure 3 below is an electrical oscillator circuit. If the voltage across the inductor L is zero when the capacitor is fully charged;

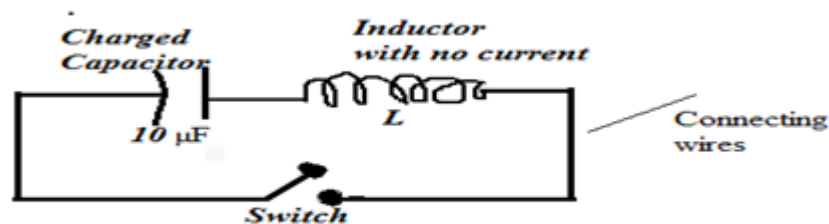

Figure 3

- (i) Show that when the switch is closed, the oscillator behaves as a simple harmonic oscillator with a period given as, $T = 2\pi\sqrt{LC}$ (4mks)
- (ii) Calculate the inductance of the inductor, L if it's periodic time 2.63 seconds. (2mrks)
- c) A spring of length l and spring constant, k was connected to join a couple to two pendulums, A and B as shown in figure 4. If the system was slightly displaced to execute simple harmonic motion.

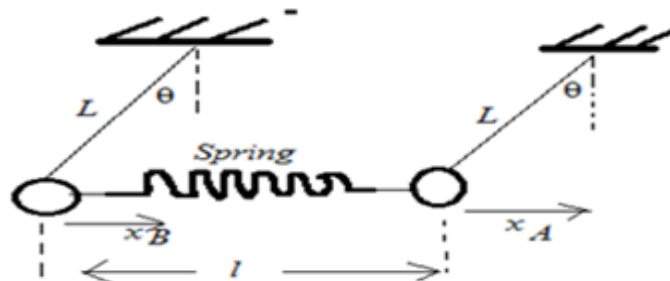

Figure 4

Show that the system executes a simple harmonic motion expressed by

$$\frac{\partial^2(x_A - x_B)}{\partial t^2} + (\omega_o^2 + 2\omega_c^2)(x_A - x_B) = 0 \text{ where } \omega_o \text{ is due to restoring force and } \omega_c^2 = \frac{k}{c} \text{ (6mrks)}$$

QUESTION FIVE (20 MKS)

- a). (i) Define the term damping. (1mrk)
 (ii) List three areas where we have damping of oscillations. (3mrks)
 b) Two coupled linear oscillators are connected as shown to display normal modes of the system.

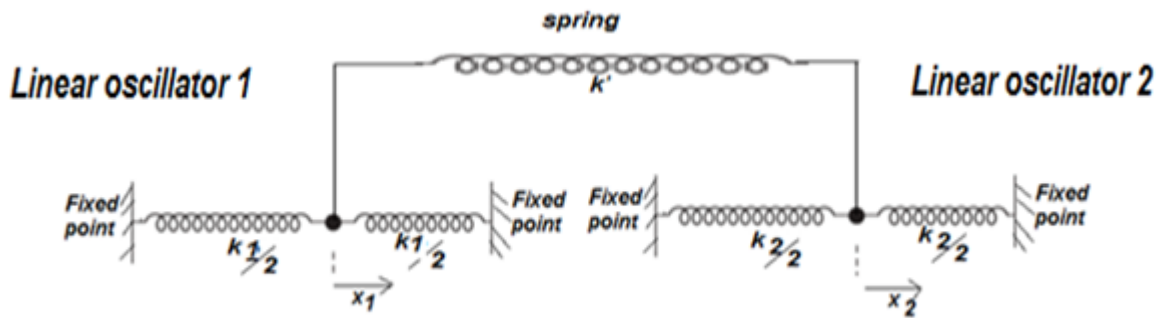

Figure 5 Two coupled oscillators

- (i) If both linear oscillators are released from rest with same displacement show that their resonant angular frequency is given by $\omega_1 = \sqrt{\frac{k}{m}}$ and the spring constant k' is not present in the solution expression for ω_1 . (6mks)
 (ii) If one oscillator is released from rest while the other is released from rest with a displacement, show that, $\omega_2 = \sqrt{\frac{k+k'}{m}}$ is the angular frequency of the oscillators system. (5mks)
 (ii) Calculate their coupled period, T if k is 4N/m and k' is 3.6N/m with mass of oscillator m is 0.02kg, find the combined period oscillation. (2mrks)
 c) A student decided to cascade two spring pendulums of constants, k_1 and k_2 respectively in series. of x . Show that to execute simple harmonic motion the period T, of their combined cascaded pendulum can be given by;
- $$T = 2\pi \sqrt{\frac{m(k_1 + k_2)}{k_1 k_2}} \text{ (5mrks)}$$

END