

TECHNICAL UNIVERSITY OF MOMBASA

FACULTY OF ENGINEERING AND TECHNOLOGY
DEPARTMENT OF ELECTRICAL & ELECTRONICS
ENGINEERING

BACHELOR OF SCIENCE IN ELECTRICAL & ELECTRONICS
ENGINEERING

EME 2113: ENGINEERING DRAWING & DESIGN II
END OF SEMESTER II YEAR I EXAMINATION

SERIES: APRIL 2016

TIME: 2 HOURS

DATE: Pick Date Select Month Pick Year

TIME: 2 HOURS

INSTRUCTIONS TO CANDIDATES

1. You are required to have the following for this examination:
 - Drawing paper/ Examination Booklet, Examination pass and student ID.
 - Drawing instruments
 - Scientific calculator
2. This paper consists of **FIVE** Questions.
3. Answer Question **ONE** (Compulsory) and any other **TWO** Questions.
4. **Do not write on the question paper.**

QUESTION ONE

Figure Q1 shows a three dimensional drawing of a V-block. You are required to:

- (a) Draw a two dimensional one view of the V-block, which clearly illustrates all the parts of the V-block with only THREE important dimensions of the assembly. Number the parts appropriately and include a parts list. The Screw and the Bracket are made of mild steel (MS) while the Block is made of cast iron (CS). (12 Marks)
- (b) Make a detailed drawing of all the parts.

(18 Marks)

QUESTION TWO

The two views shown in Figure Q2 illustrate the intersection of two unequal cylinders meeting at an angle of 45° . Complete the views and draw:

- (a) The end view projected from the front view to the right hand side.
- (b) The surface development of the branch (smaller) cylinder.

(20 Marks)

QUESTION THREE

- (a) Two views of an oblique truncated pyramid are shown in Figure Q3. Reproduce the views showing the true shape of the plan. From the views drawn, construct the surface development of the truncated pyramid taking the seam line to be the longest edge. (12 Marks)
- (b) Draw the locus of a point which is equidistant from a fixed point and a line which is 20mm away from the fixed point. Name the curve.

(8 Marks)

QUESTION FOUR

Plot the cam profile which meets the following specifications:

Shaft diameter = 10mm

Minimum diameter = 25mm

Performance:

- $0 - 90^\circ$, uniform velocity to $\frac{1}{2}$ maximum lift.
- $90^\circ - 180^\circ$, simple harmonic motion to maximum lift.
- $180^\circ - 270^\circ$, uniform acceleration to $\frac{1}{2}$ maximum lift
- $270^\circ - 360^\circ$, uniform retardation to maximum fall.

Take rotation to be clockwise.

(20 Marks)

QUESTION FIVE

(a) Define the following terms with reference to limits and fits:

- (i) Interchangeability
- (ii) Basic size
- (iii) Fit
- (iv) Fundamental deviation

(4 Marks)

(b) Briefly, explain the following types of fit:

- (i) Clearance fit
- (ii) Interference fit
- (iii) Transition fit

(3 Marks)

(c) (i) Given a hole of size $25^{+0.25}_{-0.00} \text{ mm}$ diameter with a shaft of $25^{-0.025}_{-0.050} \text{ mm}$ in diameter, determine:

- Tolerance on shaft
- Tolerance on hole
- Maximum clearance
- Minimum clearance
- Type of fit

- (ii) A hole is specified as $35^{+0.016\text{mm}}$ diameter. Determine the gauge limits for 'GO' and 'NOT GO' plug gauge to check this dimension. Take gauge maker's tolerance as 10% of the work tolerance.
- (iii) A 13.750mm shaft is to run freely in a reamed hole. The shaft tolerance is 0.015mm and the hole tolerance is 0.025mm . The desired fit requires an allowance of 0.020mm . Using basic hole system, determine the limit for the hole and shaft.

(13 Marks)

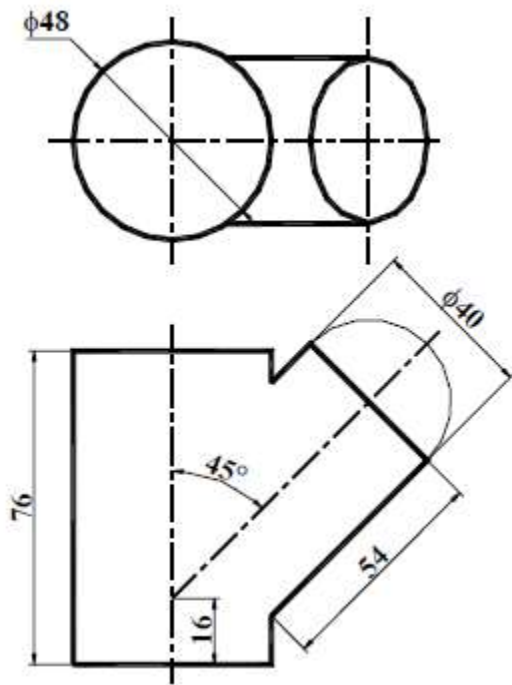

Figure Q2

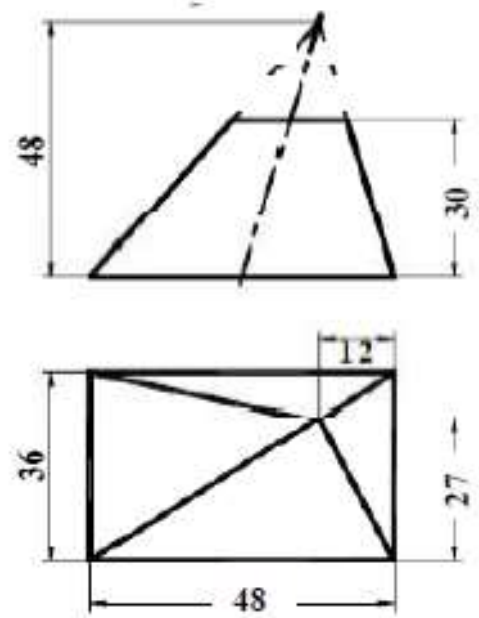

Figure Q3

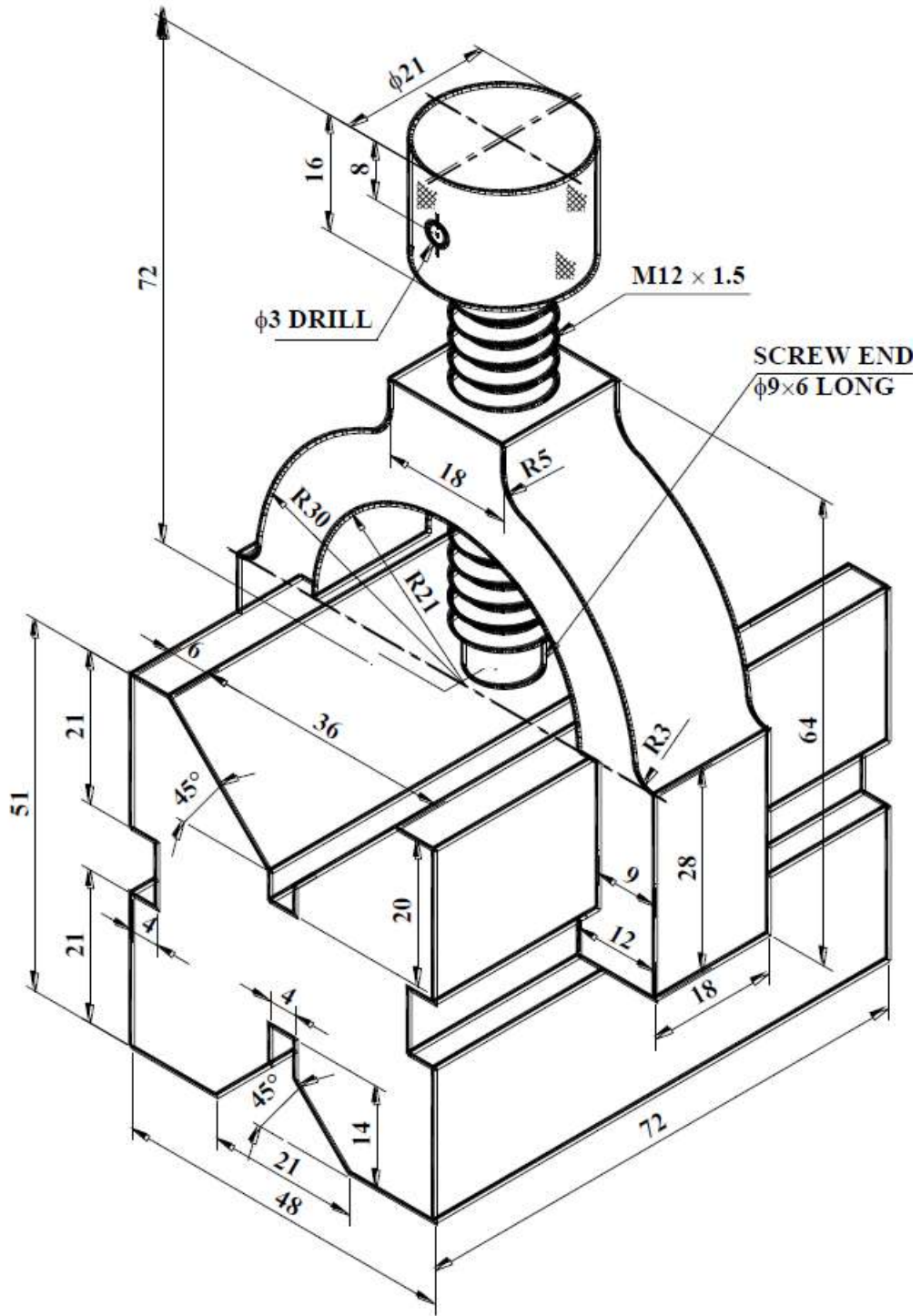

Figure Q1