



TECHNICAL UNIVERSITY OF MOMBASA

FACULTY OF ENGINEERING AND TECHNOLOGY

DEPARTMENT OF MECHANICAL & AUTOMOTIVE ENGINEERING

UNIVERSITY EXAMINATION FOR:

BACHELOR OF SCIENCE IN MECHANICAL ENGINEERING

EMG2403 : SOLID & STRUCTURAL MECHANICS III

END OF SEMESTER EXAMINATION

SERIES: APRIL 2016

• **TIME: 2 HOURS**

DATE: Pick Date May 2016

Instructions to Candidates

You should have the following for this examination

-Answer Booklet, examination pass and student ID

This paper consists of **FIVE** questions. Attempt any **THREE** questions.

Do not write on the question paper.

Question ONE

A Circular saw has an outer diameter of 1 m and an inner diameter of 100 mm. The saw is fastened to a shaft, such that there is no transfer of load between the two components (e.g fixed by a keyway). The saw material has a density of 8000 kg/m^3 and poisson's ratio 0.3. Find the maximum permissible speed of the saw if the allowable hoop stress is 240 MN/m^2 and find the maximum value of the radial stress.

(20 marks)

Question TWO

A compound thick cylinder is made by shrinking an outer steel tube 200 mm outside diameter and 1500 mm inside diameter onto a steel cylinder which has 100mm internal diameter. The compound cylinder is subjected to internal fluid pressure. The design of the cylinder is such that under the operating conditions, the maximum shear stress in each cylinder is 120 MN/m^2 .

Take $E = 21 \times 10^4 \text{ MN/m}^2$, $\nu = 0.3$

Find (a) the interface pressure due to shrinkage

(b) the diametral interference allowance

(c) the maximum allowable internal fluid pressure.

(20 marks)

Question THREE

The flange and web of a T-section are each 12 mm thick, the flange width is 100 mm and its overall depth is 100mm. The beam is simply supported over a length of 2m and it is subjected to a point load W at the mid-span.

Calculate the maximum value of W if the beam is to be designed such that yielding is permitted to penetrate the web to a depth of 20 mm.

The yield stress of the beam material is 300 MPa.

(20marks)

Question FOUR

The angle section shown in Fig.Q4 is subjected to a positive bending moment of 2KNm about the Z axis.

Determine the stresses at points A, B and C and the position of the neutral axis. All units are in mm.

(20 marks)

Question FIVE

A steel ring ABC of the dimensions shown in Fig. Q5, is firmly clamped at A. If a vertical force of 20N is applied at C, find the vertical deflection of this point. $E = 200 \text{ GN/M}^2$.

(20 marks)

Figure Q4.

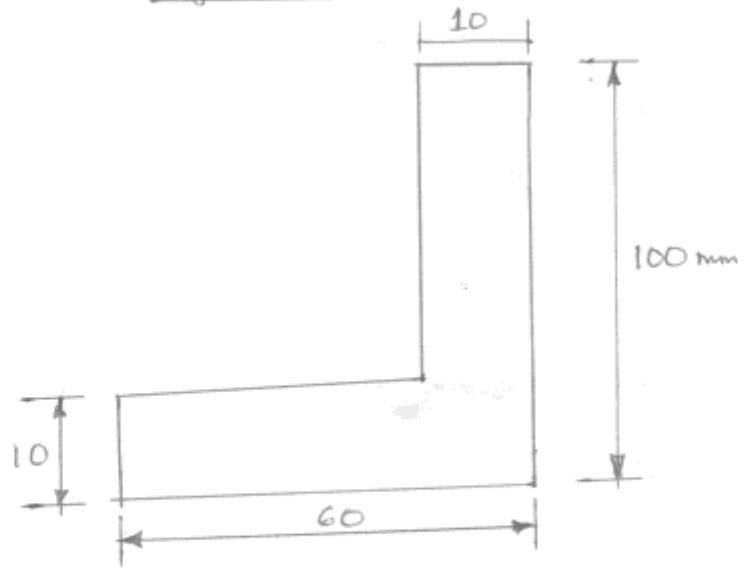

Figure Q5.

