



TECHNICAL UNIVERSITY OF MOMBASA

Faculty of Engineering and Technology
Department of Mechanical & Automotive Engineering

UNIVERSITY EXAMINATION FOR:

BSc. Mechanical Engineering

EMG 2405 : Control Engineering I

END OF SEMESTER EXAMINATION

SERIES: APRIL 2016

TIME: 2 HOURS

DATE: 15 Apr 2016

Instruction to Candidates:

You should have the following for this examination

- Answer booklet
- Non-Programmable scientific calculator

This paper consists of **FIVE** questions. Attempt question **ONE** and any other **TWO** questions.

Maximum marks for each part of a question are as shown.

Do not write on the question paper.

Question ONE (Compulsory)

- Draw a block-diagram of a typical negative-feedback, closed-loop system, labelling the individual blocks and the system inputs and outputs. State two advantages and two disadvantages of closed-loop systems when compared to open-loop systems.
(6 marks)
- Find the unit step response of a unity-feedback control system whose open-loop transfer function is given as,

$$G_o(s) = \frac{144}{s(s + 12)}$$

And also obtain,

- Delay time t_d
 - Rise time t_r
 - Peak time t_p
 - Maximum overshoot M_p
 - Settling time t_s (for 2%)
(15 marks)
- Consider the closed loop system with a unity feedback system as shown in Figure Q1a. Determine the value of gain K so that the system will have a damping ratio of 0.5.
(4 marks)

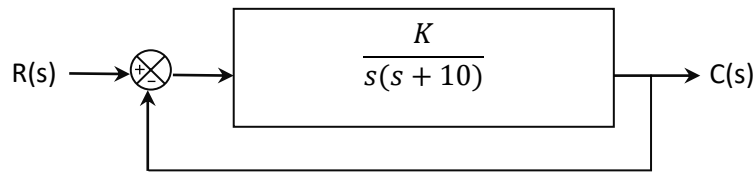

Figure Q1a

- d. It is found that the behavior of many mechanical systems can be adequately represented as a single-degree-of-freedom system as shown in Figure Q1b. The mass of the system is m kg, the linear spring stiffness is k N/m and the damping coefficient is c N/(m/s).

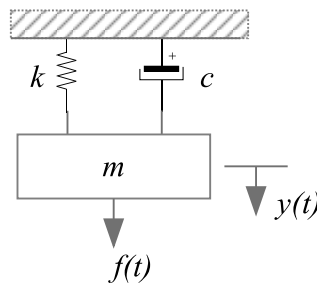

Figure Q1b

- i. Draw a free body diagram of the system and derive an expression for the relationship between the output displacement, $y(t)$, and the input force, $f(t)$.
- ii. Write an expression for the transfer function $G(s)$ which relates the output response $Y(s)$, the Laplace transform of $y(t)$, to the input $F(s)$, the Laplace transform of $f(t)$. Assume that the initial displacement and velocity are both equal to zero. **(5 marks)**

Question TWO

- a. Consider a transfer function of a system as shown in Figure Q3a

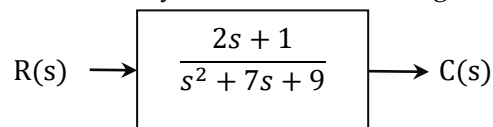

Figure Q3a

- i. Find the state equation and output equation for the phase variable representation of the transfer function.
 - ii. Draw an equivalent block diagram showing phase variables. **(10 marks)**
- b. Consider an RLC network as shown in Figure Q3b. Determine,
- i. The transfer function $G(s) = V_2(s)/V_1(s)$, of the system.
 - ii. The state space model of the RLC network. **(10 marks)**

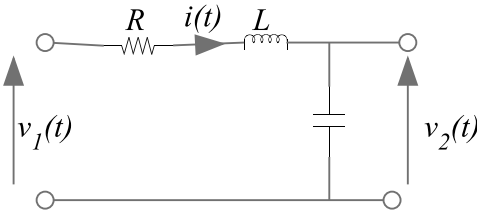

Figure Q3b

Question THREE

- State Routh-Hurwitz criteria for stability.
- Define the terms:
 - Stable.
 - Limitedly stable.
 - Unstable. (6 marks)
- Consider the closed loop system shown in Figure Q3a. Determine the range of values of K for which the system is stable. (8 marks)

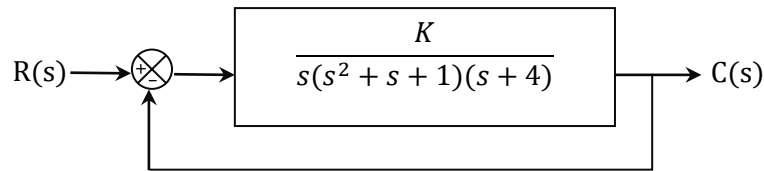

Figure Q3a

- Find the equivalent transfer function, $T(s) = C(s)/R(s)$, for the system shown in Figure Q3b. (6 marks)

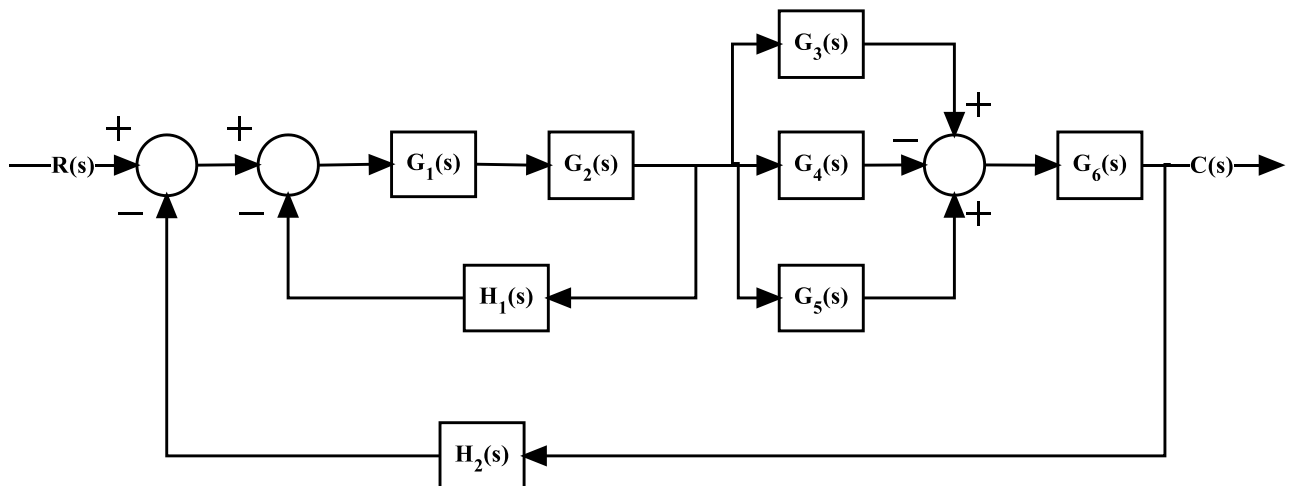

Figure Q3b

Question FOUR

- Consider a rotational mass-spring-damper system as shown in figure Q4a. Find the values of J and c to yield a response with 20% overshoot and a settling time of 2 seconds for a unit step input of torque $T(t)$. Given $k = 5\text{Nm/rad}$ (10 marks)

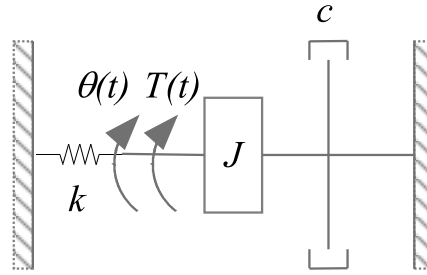

Figure Q4a

- b. Figure Q4b shows a schematic of an armature-controlled d.c. motor which essentially consists of an armature coil in a magnetic field. The armature consists of a resistance, R , and an inductance, L , in series. When current, i , flows through the armature, the coil rotates generating a torque, T , which is proportional to the current, so that $T = K_m i$. Since the armature is rotating in a magnetic field, a voltage, known as the back e.m.f. (e) will be induced in it. The back e.m.f. is proportional to the armature rotation speed, ω , so that $e = K_b \omega$. The motor drives a mechanical load with moment of inertia, I , and with a rotary viscous damping coefficient, c .

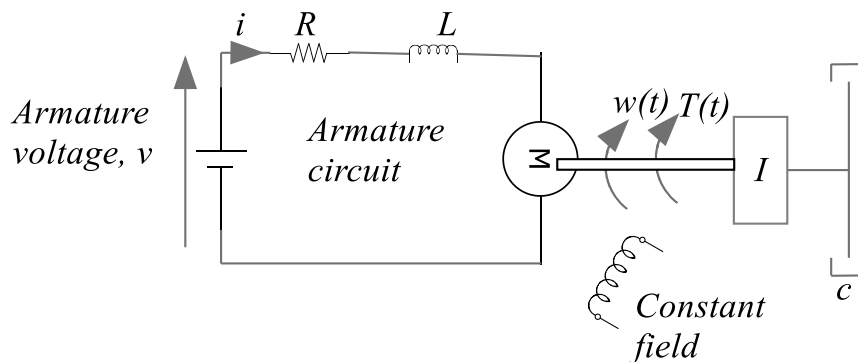

Figure Q4b

Show that the transfer function which relates $\Omega(s)$, the Laplace transform of the armature rotation speed, $\omega(t)$, to $V(s)$, the Laplace transform of the armature voltage, $v(t)$, is given by the following expression: **(10 marks)**

$$G(s) = \frac{\Omega(s)}{V(s)} = \frac{K_m}{(LIs^2 + (RI + cL)s + (Rc + K_b K_m))}$$

Question FIVE

- a. State the effect of introducing feedback on the stability of control systems. **(2 marks)**
- State the Nyquist criterion.
 - Explain how the stability of a control system may be determined from a Nyquist plot.
 - State the disadvantages of the Nyquist plot over the Bode plot.

(9 marks)

b. A control system has an open loop transfer function

$$G(s) = \frac{14}{(s + 1)(s + 2)}$$

Determine,

- i. Resonant frequency, w_r .
- ii. Resonant peak, M_r .
- iii. Deduce whether the system is stable or not.

(9 marks)