



**TECHNICAL UNIVERSITY OF MOMBASA**  
**FACULTY OF APPLIED AND HEALTH SCIENCES**

---

**DEPARTMENT OF MATHEMATICS & PHYSICS**

**UNIVERSITY EXAMINATION FOR:  
DIPLOMA IN INFORMATON TECHNOLOGY**

**APS 2103: FUNDAMENTALS OF PHYSICS**

**END OF SEMESTER EXAMINATION**

**SERIES: MAY 2016**

**TIME:2 HOURS**

**Instructions to Candidates**

You should have the following for this examination

*Answer Booklet*

*examination pass*

*mathematical table or calculator*

*student ID*

This paper consists of **FIVE** questions.

Attempt question ONE (Compulsory) and any other TWO questions.

This paper consists of 6 printed pages

**Do not write on the question paper.**

---

Coulomb's constant.  $F_e = 8.99 \times 10^9 \text{ Nm}^2/\text{C}^2$

**Question TWO (30mks)**

- a) What is the difference between a series circuit and a parallel circuit? (2mks)
- b) A 20 V battery powers a series circuit with a 15  $\Omega$  resistor and a 35  $\Omega$  resistor. What is  $R_{eq}$  and what is the current in the circuit? (2mks)
- c) i) State the majority carriers for a p-type semiconductor. (2mks)  
 ii) p-type and n-type semiconductors are made from a pure semiconductor by a process known as “doping”.  
 i) What is doping? (1mk)  
 ii) Explain how the doping produces an n-type semiconductor. (2mks)
- d) When a mass is attached to a spring, the acceleration is  $a = kx/m$  where  $a$  is acceleration,  $x$  is a length,  $m$  is mass, and  $k$  is a spring constant. Find the units of  $k$ . (3mks)
- e) State the three Newton’s laws of motion (3mks)
- f) A car of mass 1000 kg accelerates from rest to 20 m/s in a time of 5 seconds. Calculate the forward thrust of the car. (3mks)
- g) The force on an aircraft of mass 725 kg due to the engine is 15 000 N. The air resistance on the plane is 9925 N. Find the acceleration of the plane (3mks)
- h) Use mesh analysis to find the power consumption in the resistor 3  $\Omega$  (3mks)

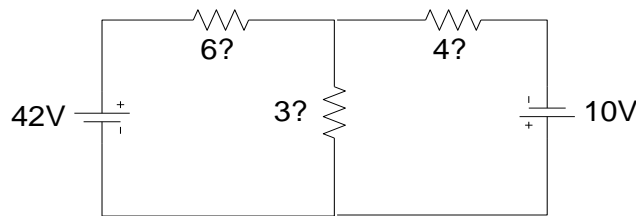

- i) The figure below shows a circuit containing three capacitors  $C_1$ ,  $C_2$  and  $C_3$

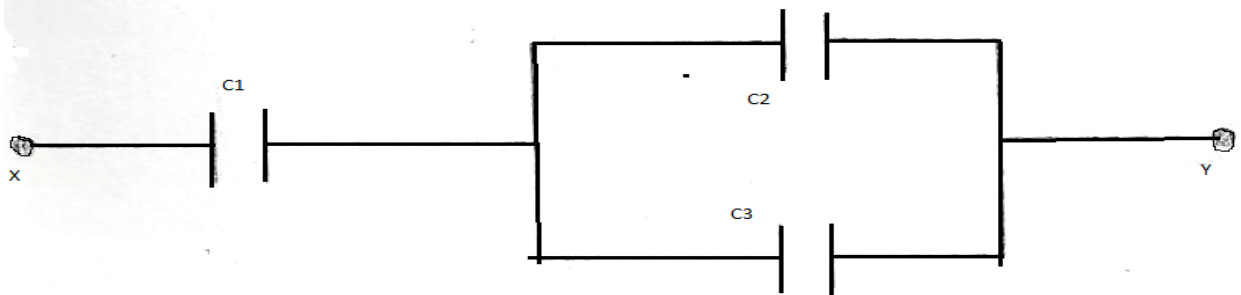

- If  $C_1 = 6\mu\text{F}$ ,  $C_2 = 4.5\mu\text{F}$  and  $C_3 = 7.5\mu\text{F}$ . Calculate the effective capacitance. (4mks)
- j) Differentiate between analog signal and digital signal using diagrams and giving example in each case (2mks)

**Question TWO (15mks)**

- a) By use of a well labeled diagram explain how a diode can be used in the rectification of AC signal (4mks)
- b) Explain why the conductivity of a metallic conductor decreases with increase in temperature while that of an intrinsic semiconductor increases with increase in temperature. (2mks)
- c) Explain what happens to the depletion layer when diode is reverse biased. (2mks)
- d) Find the current flowing and the voltage across the  $8\Omega$  resistor in the circuit. (2mks)

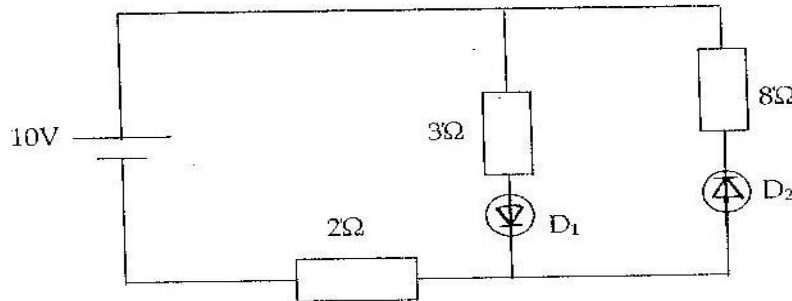

- e) The figure shows a circuit used for a full wave bridge rectification.

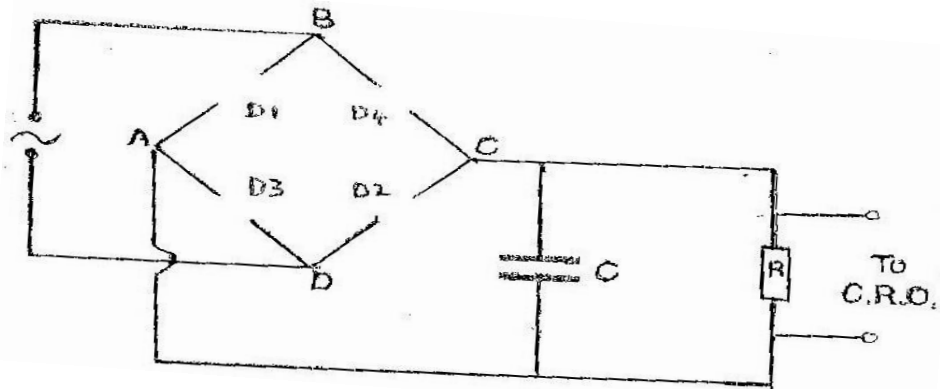

- (i) Insert diodes D1, D2, D3 and D4 to complete the circuit. (2mks)
- (ii) What is the use of capacitor C? (1mk)
- (iii) Draw a voltage – time display of the rectification observed on the C.R.O. (2mks)

**Question THREE (15mks)**

- a) Use superposition to find  $I_x$  (4mks)

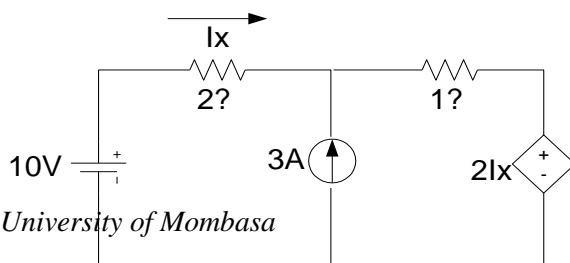

b) Determine the two mesh currents,  $i_1$  and  $i_2$ , in the circuit below. (4mks)

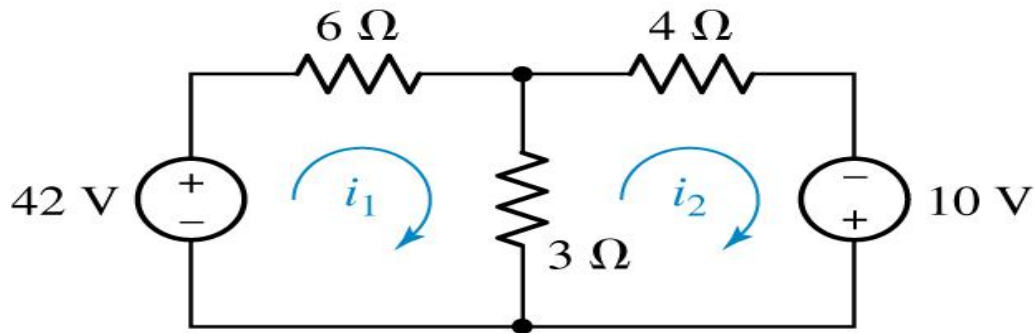

c) A generator produces 10 A at 600 V. The primary coil in a transformer has 20 turns. How many secondary turns are needed to step up the voltage to 2400 V? (3mks)

d) Find the currents  $i_1$ ,  $i_2$  and  $i_3$  in the circuit shown below (4mks)

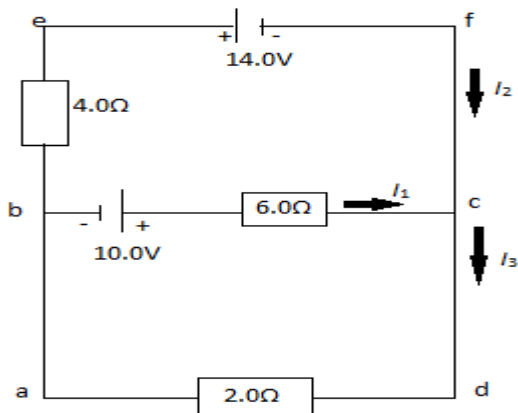

**Question FOUR (15mks)**

a) A force of  $1.6 \times 10^{-3}$  N exists between 2 charges;  $1.3 \mu\text{C}$  and  $3.5 \mu\text{C}$ . How far apart are they? (3mks)

b) What is the electric potential at point P in the diagram to the right? (4mks)

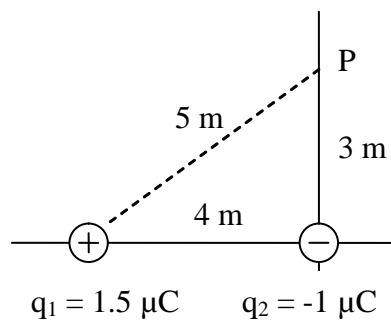

c) A charge  $q_1 = 2.00\mu\text{C}$  is located at the origin and a charge  $q_2 = -6.00\mu\text{C}$  is located at (0, 3.00)m. Find the electric potential due to these charges at point P whose coordinates are(4.00, 0)m (4mks)

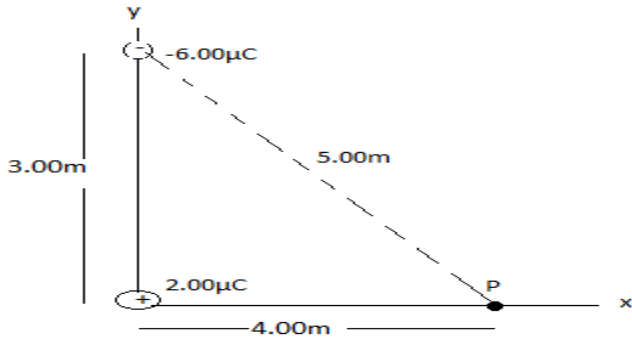

d)Find the force on the charge  $q_2$  in the diagram below due to the charges  $q_1$  and  $q_3$ . (4mks)

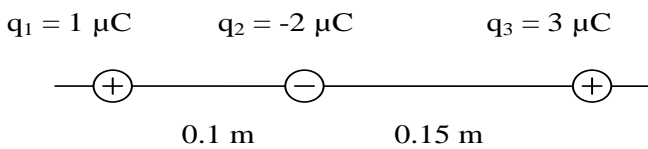

**Question FIVE (15mks)**

a)State ohm's law (1mk)

b) The figure below shows a circuit

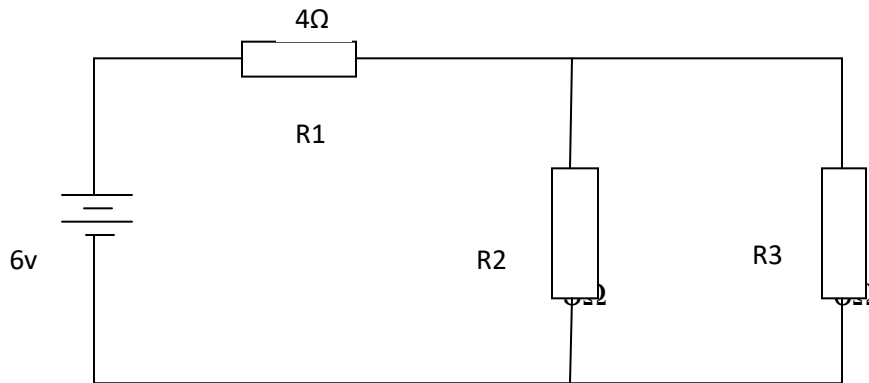

Calculate

- i)The total resistance of the circuit (3mk)
- ii)The total current flowing in the circuit (2mk)
- ii) The voltage drop across R1 (2mk)

c) Define capacitance

(1mk)

d) Figure 8 shows an arrangement of capacitors to a 12V d.c. supply.

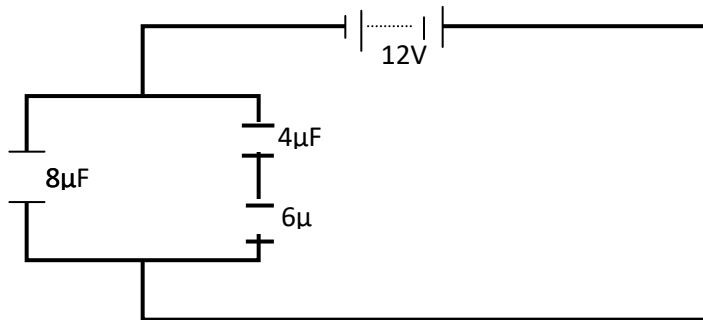

Determine

(i) Effective capacitance

(3mks)

(iii) Charge across the  $8\mu\text{F}$  capacitor.

(3mks)

**THIS IS THE LAST PRINTED PAGE**