



TECHNICAL UNIVERSITY OF MOMBASA
FACULTY OF APPLIED AND HEALTH SCIENCES

DEPARTMENT OF MATHEMATICS & PHYSICS

UNIVERSITY EXAMINATION FOR:
DIPLOMA IN ANALYTICAL CHEMISTRY

APS 2102: PHYSICS II

END OF SEMESTER EXAMINATION

SERIES: MAY 2016

TIME: 2 HOURS

Instructions to Candidates

You should have the following for this examination

Answer Booklet

examination pass

mathematical table or calculator

student ID

This paper consists of **FIVE** questions.

Attempt question ONE (Compulsory) and any other TWO questions.

This paper consists of 5 printed pages

Do not write on the question paper.

Coulomb's constant. $F_e = 8.99 \times 10^9 \text{ Nm}^2/\text{C}^2$

$m_e = 9.11 \times 10^{-31} \text{ kg}$, $m_p = 1.67 \times 10^{-27} \text{ kg}$

Question ONE (30mks)

- a) Define electric charge and give its SI unit (2mks)
- b) What is the difference between a series circuit and a parallel circuit? (2mks)
- c) State Kirchoff's laws (2mks)
- d) When the switch is closed in the figure below, the milliammeter reads 75mA. Determine the internal resistance of the cell (3mks)

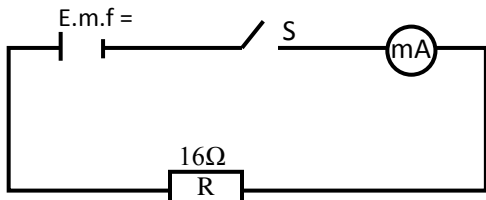

- e) A resistance wire is 2m long and has a cross sectional area of 0.50cm³. if the resistance is 2.6Ω, calculate its resistivity (3mks)
- f) Two point charges are 5.0 m apart. If the charges are 0.020 C and 0.030 C, what is the force between them and is it attractive or repulsive? (3mks)
- g) Define electric field and give its SI unit (2mks)
- h) Explain what is meant by electrical conductivity (1mk)
- i) A material has a conductivity of 10⁶ S m⁻¹. What is its resistivity? (2mks)
- j) What is the electric potential 50 cm from a point charge q = 1 x 10⁻⁶ C? (2mks)
- k) Two capacitors of capacitance 2μF and 1μF are connected in parallel. A potential difference of 3v is applied across them. Find the energy stored in the combination (3mks)
- l) Suppose the magnetic flux in the presence of a coil having 240 loops is changing at a rate of 0.25 Wb s⁻¹. What is the induced emf? (3mks)
- m) Explain why a digital signal is superior to an analog signal (2mks)

Question TWO (15mks)

- a) What is the electric potential at point P in the diagram to the right? (4mks)

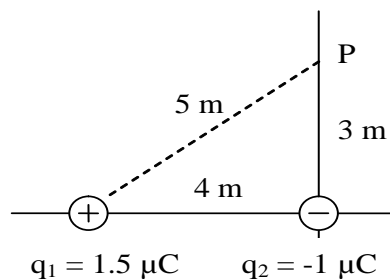

b) Study the circuit diagram below and answer the questions that follow.

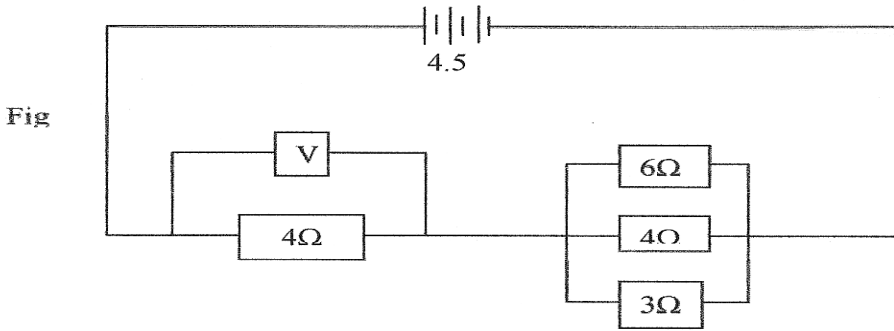

(i) Calculate the effective resistance of the circuit. (3mks)

(ii) Find the voltmeter reading. (3mks)

c) A cell drives a current of 3.2A through a 2.8Ω resistor. When it is connected to 1.6Ω resistor, the current that flows is 5A. Find the e.m.f. (E) and internal resistance of the cell. (4mks)

Question THREE(15mks)

a) A circuit consists of a cell of emf 1.6 V in series with a resistance 2.0 Ω connected to a resistor of resistance 3.0 Ω in parallel with a resistor of resistance 6.0 Ω Determine the total current drawn from the cell and the potential difference across the 3.0 Ω resistor. (4mks)

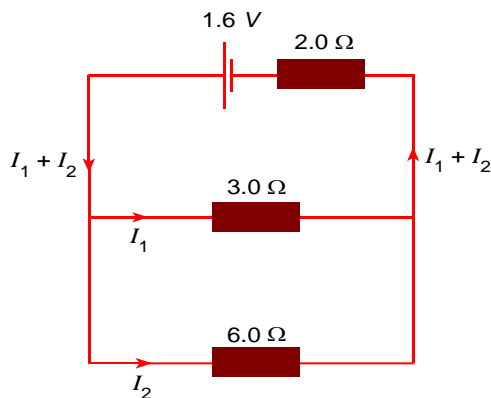

b) A single loop circuit contains two resistors and two batteries as shown in the figure below. (Neglect the internal resistance of the batteries). Find the current in the circuit. (4mks)

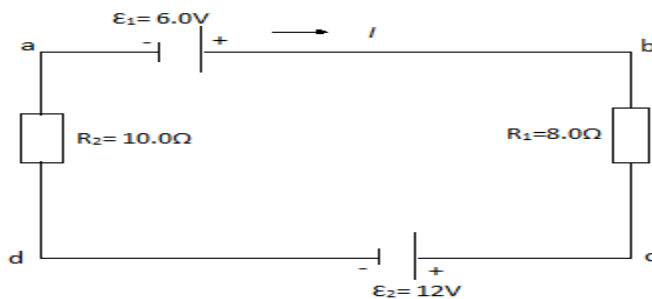

c) A pure copper wire has a radius of 0.5mm, a resistance of 1 MΩ, and is 4680 km long. What is the resistivity of copper? (3mks)

d) Differentiate between Ohmic and non-ohmic conductors giving examples two examples in each case (4mks)

Question FOUR (15mks)

a) What do we mean by the term electrical resistance and what causes it in a given material (2mks)

b) Explain briefly the theory of potentiometer and give its application (3mks)

c) Calculate the minimum and maximum values of V_{out} that we can get by adjusting the potentiometer (3mks)

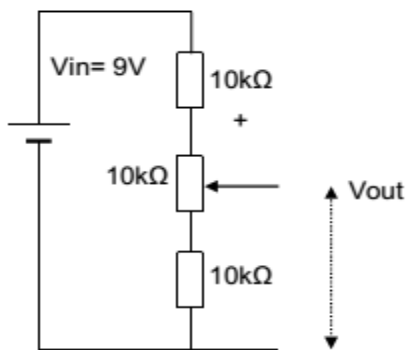

d) The figure below shows an arrangement of capacitors to a 12V d.c. supply.

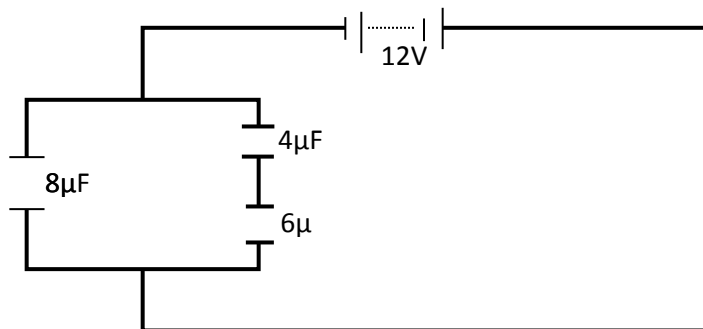

Determine

(i) Effective capacitance (3mks)

(iii) Charge across the 8μF capacitor. (3mks)

Question FIVE (15mks)

a) Explain why when the switch is closed in the first circuit, the ammeter in the second reads a current (but just for an instant). (3mks)

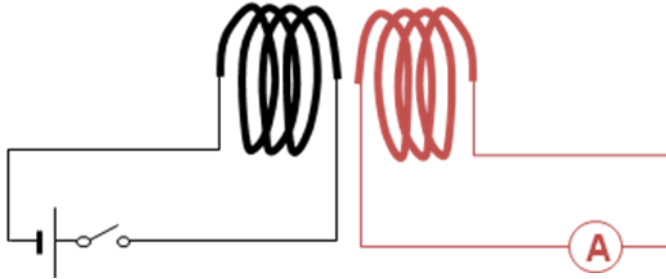

b) Define the term electronics and electrical technology (2mks)

c) Define the following terms as used in electronics (3mks)

d) What are the advantages of digital signals (2mks)

e) Define the following terms

i) Semiconductors: (1mk)

ii) Diode: (1mk)

f) Draw diagrams showing a forward biased diode and reverse biased bias (3mks)

THIS IS THE LAST PRINTED PAGE