



TECHNICAL UNIVERSITY OF MOMBASA

FACULTY OF ENGINEERING AND TECHNOLOGY

DEPARTMENT OF MECHANICAL & AUTOMOTIVE ENGINEERING

UNIVERSITY EXAMINATION FOR:

DIPLOMA IN MARINE ENGINEERING

EMR 2116: TECHNICAL DRAWING II

END OF SEMESTER EXAMINATION

SERIES: APRIL 2016

TIME: 3 HOURS

DATE: 15 May 2016

Instructions to Candidates

You should have the following for this examination

-Answer Booklet, examination pass and student ID, Drawing paper A2

This paper consists of **FIVE** questions. Attempt question ONE (Compulsory) and any other TWO questions.

Do not write on the question paper.

Question ONE

Figure QN1 shows parts of a TOOL POST. Assemble the parts with the screw fully fastened and draw FULL SIZE in First angle orthographic projection the following views;

(a)Sectional front elevation along vertical cutting plane viewed from C

(b)End elevation

(c)Plan

Include SIX leading dimensions and symbol of projection.

(30 marks)

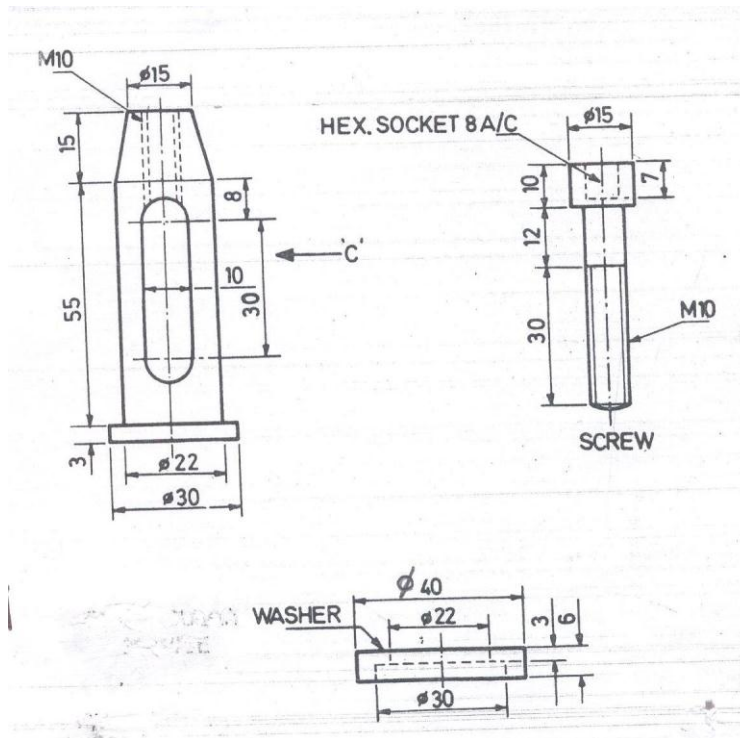

Figure Qn1.

Question TWO

A pipe 50mm diameter meets a square as shown in Figure QN2. Copy the given views and draw

- Complete plan
- Curve of interpenetration
- Surface development of the branch pipe

(20 marks)

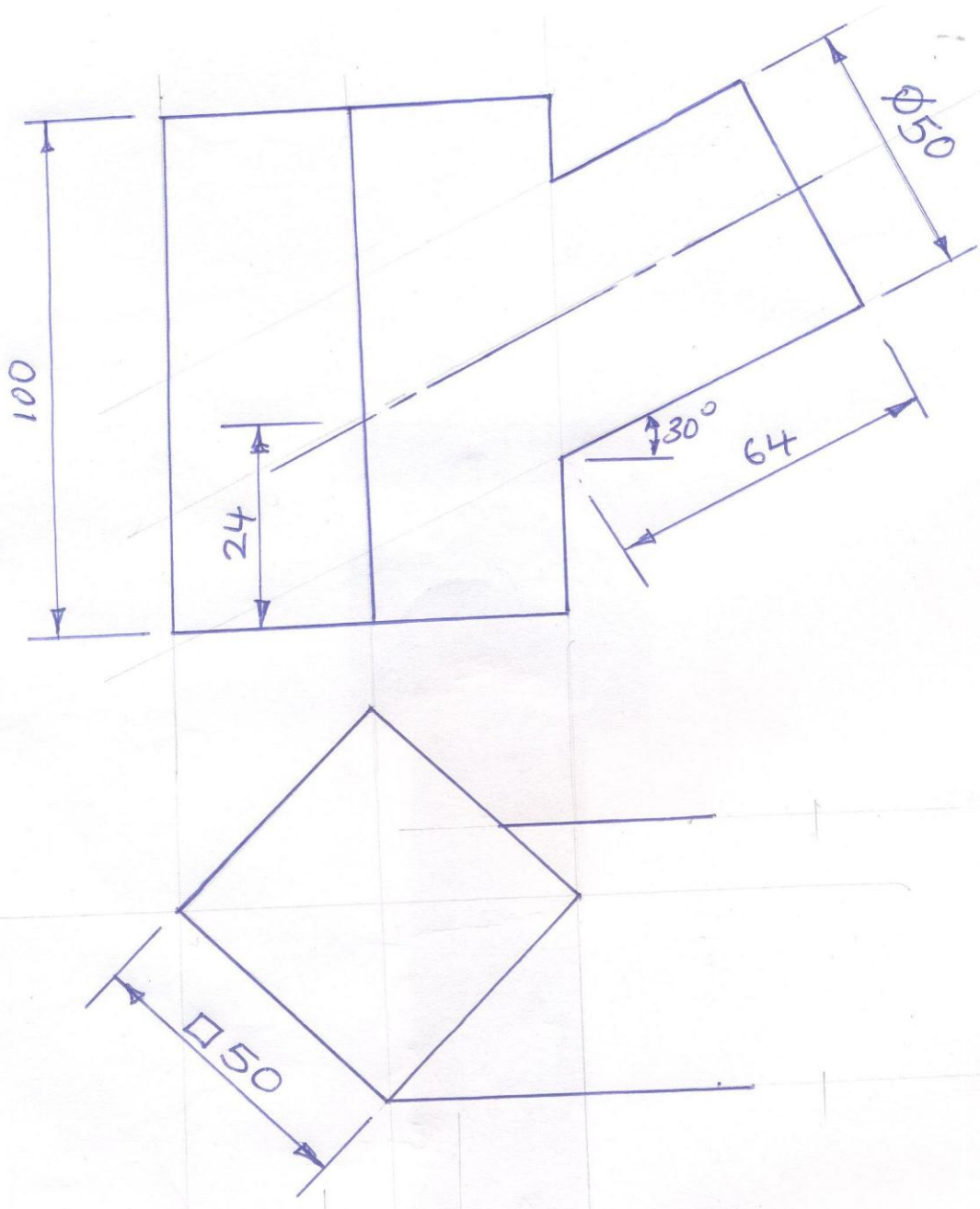

Figure QN2.

Question THREE

Figure QN3 shows a truncated pentagonal base prism. Copy the given views and draw:-

- (a) Complete plan
- (b) End elevation viewed from arrow EE
- (c) True shape
- (d) Surface development of the truncated prism

[20 marks]

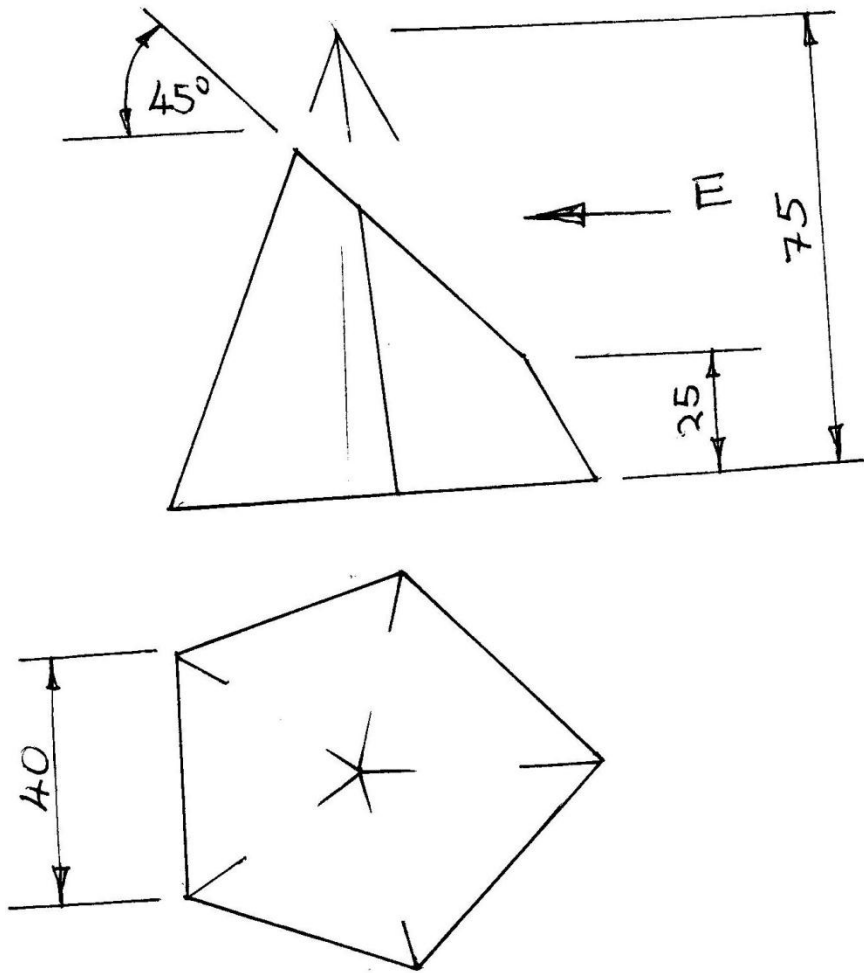

Figure QN3.

Question FOUR

Figure QN4 shows three views of a BRACKET in third angle projection. Draw an ISOMETRIC view of the bracket exposing most of the features.

(20 marks)

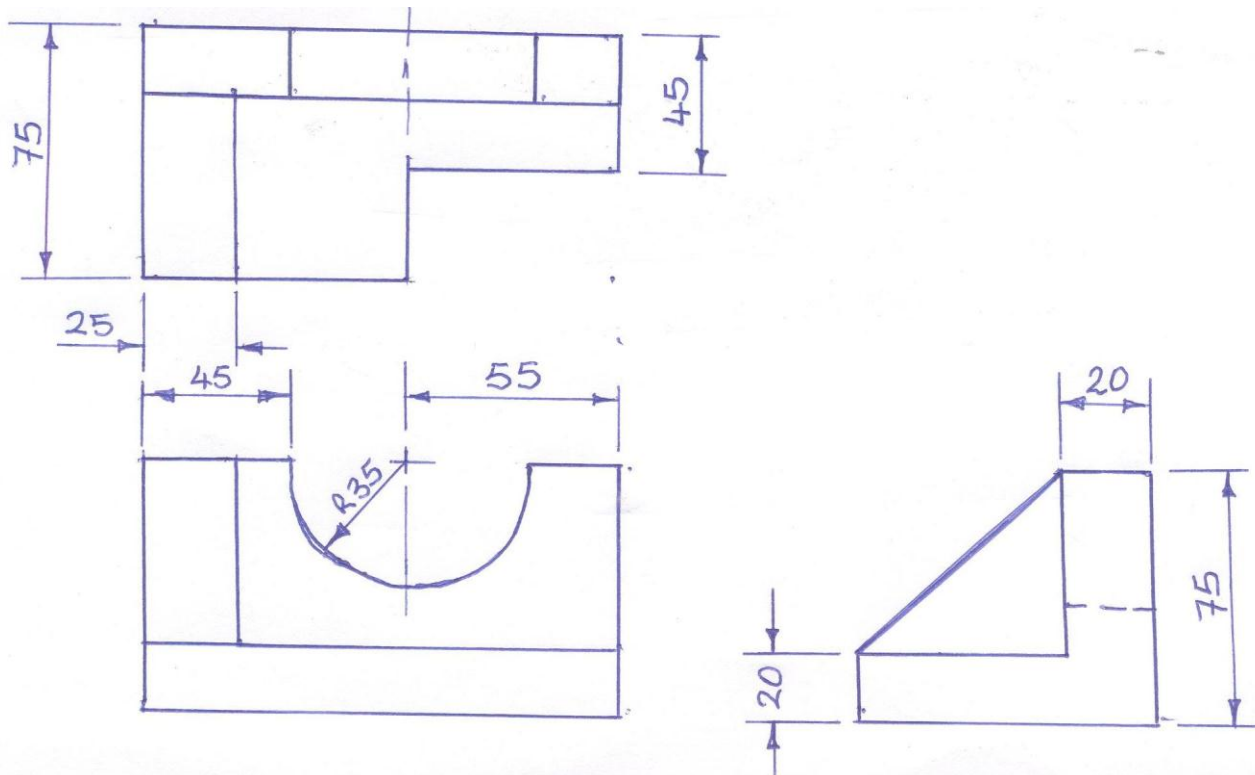

Figure QN4

Question FIVE

Three views of a BRACKET drawn in First angle orthographic projection are shown in Figure QN5. Draw an OBLIQUE view of the bracket taking oblique rules into consideration.

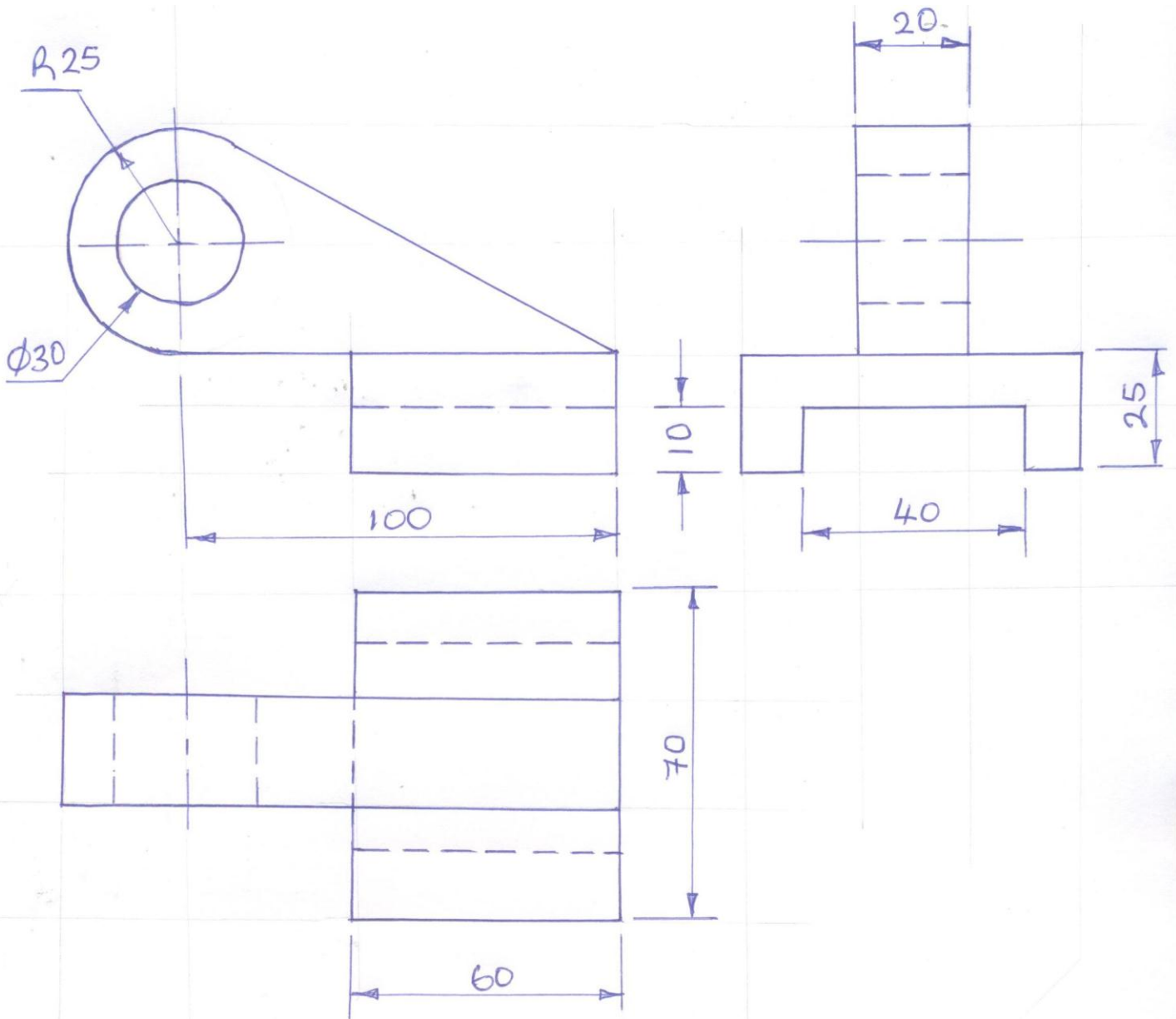

Figure QN5.