

PAPER I

TECHNICAL UNIVERSITY OF MOMBASA
FACULTY OF ENGINEERING AND TECHNOLOGY
DEPARTMENT OF MECHANICAL & AUTOMOTIVE
ENGINEERING

DIPLOMA IN MARINE ENGINEERING
EMG 2314: APPLIED MECHANIC IV
END OF SEMESTER II YEAR III EXAMINATION
SERIES: APRIL 2016
TIME: 2 HOURS

DATE: Pick Date Select Month Pick Year

TIME: 2 HOURS

INSTRUCTIONS TO CANDIDATES

1. You are required to have the following for this examination:
 - Examination Booklet, Examination pass and student ID.
 - Drawing instruments
 - Scientific calculator
2. This paper consists of **FIVE** Questions.
3. Answer **ANY THREE** Questions.
4. Maximum marks for each part of a question are shown.
5. Take gravitational acceleration, $g = 9.81\text{m/s}^2$ where applicable.
6. Show all your working on the answer booklet
7. **Do not write on the question paper**

PAPER I

QUESTION ONE

- (a) A single clutch is to have an internal and external radii, r_1 and r_2 respectively. If the limiting coefficient of friction is μ and the axial spring loading is W , show that the maximum torque transmitted by the clutch is given by:

(i) $\frac{2}{3} \mu W \left[\frac{r_2^3 - r_1^3}{r_2^2 - r_1^2} \right]$; assuming uniform pressure intensity on the contact surfaces

(ii) $\mu W \left[\frac{r_2 + r_1}{2} \right]$; assuming uniform wear of contact surfaces.

(12 arks)

- (b) A multi-plate clutch has 4 pairs of contact surfaces, each 240mm external diameter and 120mm internal diameter. Assuming uniform pressure, find the total spring load pressing the plates together to transmit 25KW at 1600rev/min. Take coefficient of friction to be 0.3.

If there are 6 springs each of stiffness 15KN/m and each of the contact surfaces has worn away by 1.25mm, determine the maximum power that can be transmitted at the same revolutions/ minute, assuming uniform wear and the same coefficient of friction.

(8 Marks)

QUESTION TWO

- (a) A cone clutch is to be designed in order to have inner and outer radii of r_1 and r_2 respectively. If W is the axial load to be transmitted to the clutch and β is the semi-angle of the cone, show that the frictional torque transmitted by the clutch, assuming uniform wear, will be given by:

$$\mu W \left[\frac{r_2 - r_1}{2} \right] \cos ec \beta$$

Where, μ is the coefficient of friction between the contact surfaces

(8 Marks)

- (b) A cone clutch is required to transmit 200Nm of torque at 1250rev/min. The large diameter of the clutch is 350mm and the cone has a face angle of 6.25° with a conical surface width of 65mm. The coefficient of friction of the contact surfaces is 0.2. Assuming uniform wear, determine:

- i) The axial force required to transmit the torque
- ii) The least axial force necessary to hold the clutch in engagement
- iii) The maximum normal pressure

(7 Marks)

PAPER I

(c) Considering the same clutch in part (b) above, with the same specifications but assuming uniform pressure, determine:

- i) The axial force required to transmit the torque
- ii) The maximum power transmitted

(5 Marks)

QUESTION THREE

(a) Apart from spur gears, state any other **THREE** types of gear wheels.

(3 Marks)

(b) A simple gear train has 3 gears. Gear A is the input and has 50 teeth. Gear C is the output and has 150 teeth. Gear A rotates at 1500 rev/min with a torque of 1200NM. Determine:

- i) The output speed
- ii) The output power and output torque if the efficiency of the gear train is 75%

(5 Marks)

(c) A drive is transmitted between two parallel shafts by spur gears. The module is 3mm and the shafts centre distance is 13.5cm. The velocity ratio of the wheels is 5:1. If the teeth are 20° involute and the pinion is transmitting 10KW at 600rev/min, determine:

- (i) The number of teeth in the pinion and the wheel.
- (ii) The maximum force between the teeth.
- (iii) The force tending to separate the teeth.

(12 Marks)

QUESTION FOUR

(a) In a compound gear train shown in Figure Q4 (a), gear A is the input and revolves at 1200rev/min clockwise viewed from the left end. The input torque is 30Nm and the efficiency of the gear train is 70%. The number of teeth on the gears is: A=50, B=150, C=30 and D=60 teeth. Determine:

- i) The output speed and its direction
- ii) The output torque and output power

(6 Marks)

(b) In a worm and worm-wheel lifting gear, the wheel has 30teeth and worm has two starts. The load wheel is 36cm diameter and the effort is applied to the worm shaft at the end of a lever 42cm long. An effort of 100N is needed to raise a load of 204Kg. Determine the efficiency of the machine.

(5 Marks)

PAPER I

- (c) Figure Q4 (c) shows an epicyclic gear train in which wheel D is held stationary by the shaft A and arm B is rotated 200rev/min. The wheels E and F are fixed together and rotate freely on the pin carried by the arm. The wheel G is rigidly attached to the shaft C. The number of teeth on the wheels is: E=20, F=40 and G=30 teeth. If the system forms a reverted gear train and the module is common for all the gears, determine:

- (i) The number of teeth of D.
- (ii) The speed of the shaft C and state its direction of rotation relative to that of B

(9 Marks)

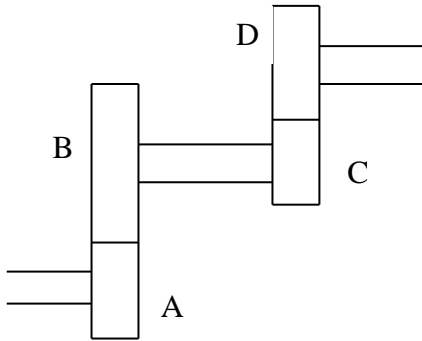

Figure Q4 (a)

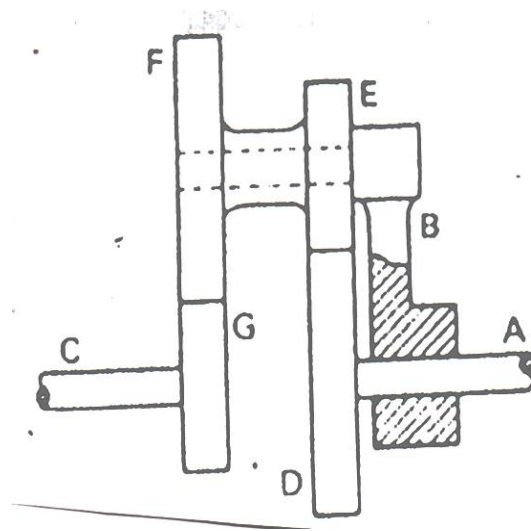

Figure Q4 (c)

QUESTION FIVE

- (a) With the aid of a neat diagram, show that the power transmitted by a flat belt drive is given by:

$$T_1 \left(1 - \frac{1}{e^{\mu\theta}} \right) V$$

Where:

T_1 – Tight tension in the belt

μ – Coefficient of friction

θ – Angle of lap

(7 Marks)

PAPER I

(b) Two pulleys are 100mm and 150mm in diameter and their centres are 400mm apart. If the coefficient of friction between the materials is 0.3, and the maximum tensile force in the belt is 2000N, determine the power that can be transmitted for a belt speed of 24m/s if:

- i) The belt is flat.
- ii) The belt is a “V-type” with an included angle of 40°

(6 Marks)

(c) A crossed belt drive is to transmit 7.5 KW at 1000rev/min of the smaller pulley. The smaller pulley has a diameter of 250mm, the velocity ratio is 2 and the centre distance is 1.25m. It is desired to use a flat belt 6mm thick with an expected coefficient of friction of 0.3. If the maximum allowable stress in the belt is 1.7MN/m^2 and the belt has a density of 970 Kg/m^3 , determine the necessary belt width.

(7 Marks)