



TECHNICAL UNIVERSITY OF MOMBASA

Faculty of Engineering and Technology

DEPARTMENT OF MEDICAL ENGINEERING
DIPLOMA IN MEDICAL ENGINEERING
DME 215 Y2S1

EHL 2201
MEDICAL ELECTRONICS II

SPECIAL SUPPLEMENTARY EXAMINATIONS

SERIES: SEPT. 2017

TIME: 2 HOURS

INSTRUCTIONS TO THE CANDIDATE:

1. You should have the following for this examination:
 - Answer Booklet
 - Scientific Calculator
 - Drawing Instrument
2. This paper consists of **FIVE** questions. Answer Question **ONE (COMPULSORY)** and any other **TWO** Questions.
3. Do not write on the question paper.
4. This paper consists of **THREE** printed pages.

QUESTION ONE

- (a) (i) State **THREE** characteristics of small signal amplifiers

(ii) Describe with the help of a diagram the operation of NPN common emitter amplifier (10 marks)
- (b) (i) State **TWO** ways of classifying power amplifiers

(ii) Explain the differences between class A, B and C power amplifiers using simple waveforms (8 marks)
- (c) (i) State **THREE** characteristics of an ideal opamp
(ii) Draw a non inverting opamp circuit and derive an expression of its output voltage gain
(iii) Give **THREE** applications of opamps (12 Marks)

QUESTION TWO

- (a) (i) The output characteristics of a silicon NPN transistor connected to a supply voltage of 6V and load resistor of 1.5 K Ω are given below.

VCE	Collector current (mA)				
	I _B =0	I _B =20 μ A	I _B =40 μ A	I _B =60 μ A	I _B =80 μ A
1	0.2	1.15	1.9	2.8	3.7
4	0.3	1.25	2.05	2.95	4.0
7	0.4	1.35	2.20	3.25	4.3

- (I) Plot the characteristics curves and load line
(II) Determine the current gain the base current is varied from 20 μ A to 60 μ A
(10 marks)

- (b) (i) Describe with the help of a suitable diagram the operation of a JFET
(ii) State any three advantages of FETs over BJTs (10 marks)

QUESTION THREE

- (a) Describe with the aid of a diagram the operation of a class A Power amplifier (10 marks)
- (b) (i) Show that the efficiency of a class A amplifier is approximately 25 %
(ii) State three advantages of class A power amplifier (10 marks)

QUESTION FOUR

- (a) (i) Describe the following terms as applied to operational amplifiers
(I) Open loop voltage gain
(II) Common mode rejection ratio

(ii) With the aid of a diagram, derive the expression of an opamp when used as an integrator (10 marks)
- (b) (i) explain the meaning of a differential amplifier

(ii) The figure shown in Fig. Q4 is a non inverting opamp

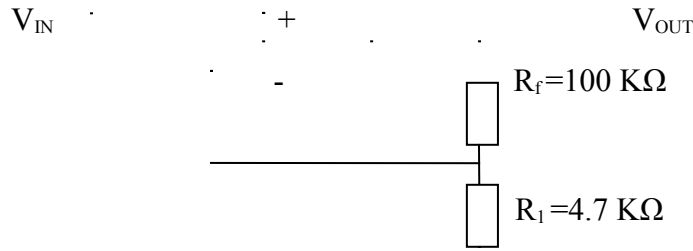
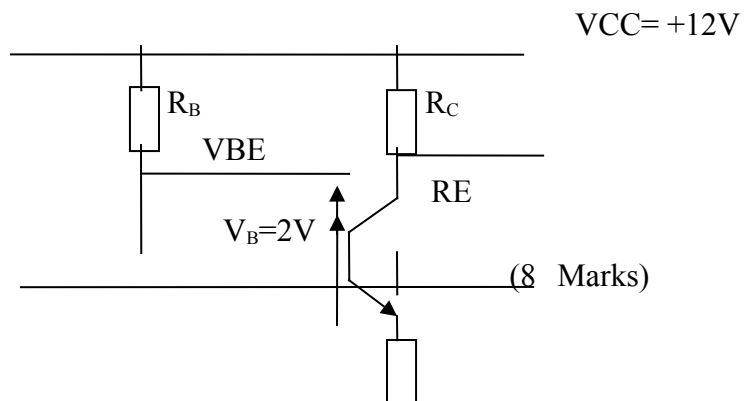

Fig. Q4

- (i) Derive an expression of closed loop voltage gain
- (ii) Calculate the Closed loop voltage gain of the Fig. Q4 (10 marks)

QUESTION FIVE

- (a) In **FIG. Q5** calculate the values of R_B , R_E and R_C . Given $h_{FE}=100$, $V_{CE}=6V$, $V_{BE}=0.7$, $I_B=20\mu A$ and $V_B=2V$.



- (b) (i) With a help of a diagram describe the principle of operation of Colpits oscillator, giving an expression of oscillation
- (ii) State two applications of oscillators in Medical Equipment (12 marks)