



TECHNICAL UNIVERSITY OF MOMBASA

Faculty of Applied and Health Sciences

Department of Mathematics and Physics

UNIVERSITY EXAMINATION FOR:

Bachelor of Technology in Applied Chemistry

APS 4103 Physics for Chemists

END OF SEMESTER EXAMINATION

SERIES: May 2016

TIME: 2 Hours

DATE:

Instructions to Candidates

You should have the following for this examination

-Answer Booklet, examination pass and student ID

This paper consists of five questions. Attempt Question One and any other two questions.

Do not write on the question paper.

Important constants

Permittivity of free space $\epsilon_0 = 8.85 \times 10^{-12} \text{ C}^2 \text{ N}^{-1} \text{ m}^{-2}$

Acceleration due to gravity $g = 9.81 \text{ ms}^{-2}$

$\frac{1}{4\pi\epsilon_0} = 9 \times 10^9 \text{ Fm}^{-2}$

Electric charge $e = 1.63 \times 10^{-19} \text{ C}$

Question One (30 marks)

- List two uses and two limitations of dimensional analysis. (4 marks)
- Explain the importance of seat belts and speed governors in curbing road accident fatalities. (4 marks)
- An object of mass m lies on a smooth plane. When the plane is gradually lifted from the ground, it is observed that the object begins to slide when the angle between the plane and the ground is 45° . Calculate the coefficient of static friction. (2 marks)
- State coulombs law. (2 mark)
- What is meant by the term conservation of charge? (1 mark)
- The charges on three identical spheres are $10 \mu\text{C}$, $-6 \mu\text{C}$ and $13 \mu\text{C}$. the spheres are touched together and then separated. What are the charges on the three spheres now? (3 marks)
- List at least three dissimilarities between Coulomb force and Gravitational force. (3 marks)

- h. Two resistors 4 Ω and 6 Ω are connected in series. If the voltage across the 4 Ω is 2 V, find the source voltage. (3 marks)
- i. A parallel plate capacitor of plate area 0.1 m² and a separation of 0.001 m is charged to 100 V. Calculate the capacitance of the capacitor and the charge on each plate. (4 marks)
- j. State Kirchhoff's laws. (2 marks)
- k. Define electrical resistivity of a material and state the SI units. (2 marks)

Question Two (20 marks)

- a. State the laws of friction (3 marks)
- b. What is meant by the term linear momentum? (1 mark)
- c. Explain how force is related to linear momentum (1 mark)
- d. Give the mathematical expression for Newton's second law of motion and state how the Newton is defined from this law (2 marks)
- e. A large cardboard box of mass 0.75 kg is pushed across a horizontal floor by a force of 4.5 N. The motion of the box is opposed by a frictional force of 1.5 N and air resistance force kv^2 where $k = 6 \times 10^{-2} \text{ kg/m}$ and v is the speed of the box.
 - i. find the speed of the box if the box is not accelerating (4 marks)
 - ii. calculate the force the floor is exerting on the box (2 marks)
- f. A body of mass 10 kg is pulled up a rough surface inclined at an angle of 30° to the horizontal by a 60 N force. If the frictional force between the plane and the body is 20 N find:
 - i. the acceleration of the body up the plane (5 marks)
 - ii. the normal reaction (2 marks)

Question Three (20 marks)

- a. Three charges $q_1 = -9 \mu\text{C}$, $q_2 = 8 \mu\text{C}$ and $q_3 = 2 \mu\text{C}$ are located at the corners of an equilateral triangle of sides 0.15 m. Find the net electrostatic force exerted on q_3 . (5 marks)
- b. Two point charges q_1 and q_2 of $8 \mu\text{C}$ and $-8 \mu\text{C}$ respectively are placed 0.1 m apart as shown in Figure 1. Find the electric fields at
 - i. A (3 marks)
 - ii. B (3 marks)
 - iii. C (5 marks)

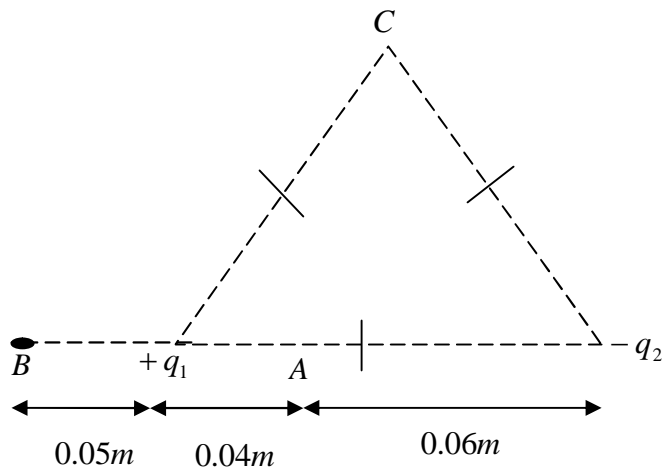

Figure 1: Charges

- c. Define electric potential due to a point charge. (1 mark)
- d. Two point charges $+2 \text{ nC}$ and -3 nC separated by a distance of 20 cm . Find the potential at a point P midway between the charges. (3 marks)

Question Four (20 marks)

- a. For the circuit of Figure 2 calculate the (I) charges on, and (II) the potential difference across
- X (4 marks)
 - Y (3 marks)

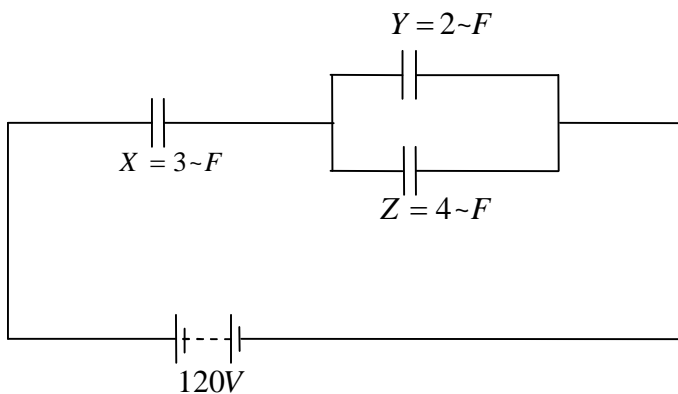

Figure 2 : Capacitors

- b. Show that the energy stored in a capacitor is $w = \frac{1}{2} CV^2$ (4 marks)
- c. A $5 \mu\text{F}$ capacitor is charged by a 12 V supply and is then discharged through a $2 \text{ M}\Omega$ resistor.
- what is the charge on the capacitor at the start of the discharge? (2 marks)

- ii. what is the charge on the capacitor after 5 s (3 marks)
- iii. the current in the circuit after 5 s (4 marks)

Question Five (20 marks)

- a. State ohms law (1 mark)
- b. When a $10\ \Omega$ resistor is connected across the terminals of a cell of EMF E and internal resistance r , a current of $0.1\ \text{A}$ flows through the resistor. If the $10\ \Omega$ resistor is replaced with a $3\ \Omega$ resistor, the current increases to $0.24\ \text{A}$. Find E and r . (5 marks)
- c. In the circuit of Figure 3, find
 - i. effective resistance (3 marks)
 - ii. total current (2 mark)

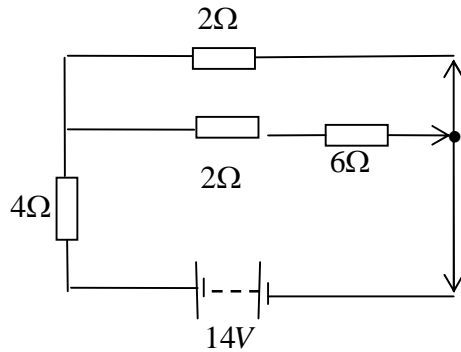

Figure 3: Resistors

- d. In Figure 4, use Kirchhoff's law to find
 - i. I_1 (3 marks)
 - ii. I_2 (3 marks)
 - iii. I_3 (3 marks)

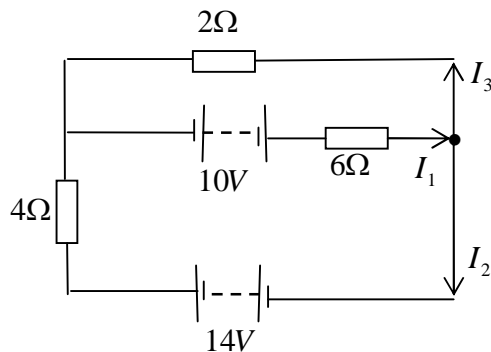

Figure 4: Resistors