



# TECHNICAL UNIVERSITY OF MOMBASA

FACULTY OF APPLIED & HEALTH SCIENCES

MATHEMATICS & PHYSICS DEPARTMENT

## UNIVERSITY EXAMINATION FOR:

BACHELOR OF TECHNOLOGY IN APPLIED PHYSICS AND BACHELOR OF TECHNOLOGY IN ENVIRONMENTAL PHYSICS & RENEWABLE ENERGY

APS 4105: ELECTRICITY & MAGNETISM I

END OF SEMESTER EXAMINATION

**SERIES: MAY 2016**

**TIME: 2 HOURS**

**DATE: MAY 2016**

### Instructions to Candidates

You should have the following for this examination

-Answer Booklet, examination pass and student ID

This paper consists of FOUR questions.

**Do not write on the question paper. Answer question ONE (compulsory) and any other two questions.**

DATA: Permeability of vacuum/free space,  $\mu_0 = 4\pi \times 10^{-7} \text{ Hm}^{-1}$

Permittivity of vacuum/ free space,  $\epsilon_0 = 8.85 \times 10^{-12} \text{ Fm}^{-1}$

Electron charge,  $q = 1.602 \times 10^{-19} \text{ C}$

Mass of electron,  $m_e = 9.11 \times 10^{-31} \text{ kg}$

Proton mass,  $m_p = 1.67 \times 10^{-27} \text{ kg}$

### Question ONE [ 30 Marks]

- (a) (i) State Biot – Savart law for a current element. (1 Mark)
- (ii) A circular loop of radius  $a$  carries a current  $I$ . Find the magnetic field due to the axis of the loop at a distance  $x$  from the centre. (4 Marks)
- (b) (i) A straight current carrying wire length  $l$  is placed in a uniform magnetic field  $\vec{B}$ . Give an expression for the magnetic force on the wire. (2 Marks)
- (ii) A 45-cm length of straight wire which carries a 6A current is placed in a magnetic field where it experiences a force of 0.05N. Determine the magnetic field given that it is directed at an angle of  $30^\circ$  to the wire. (3 Marks)

- (c) (i) State Kirchhoff's laws (2 Marks)  
(ii) Use the Kirchhoff's laws to calculate the amount of current flowing through  $1.0\ \Omega$  resistor shown in figure 1. (3 Marks)

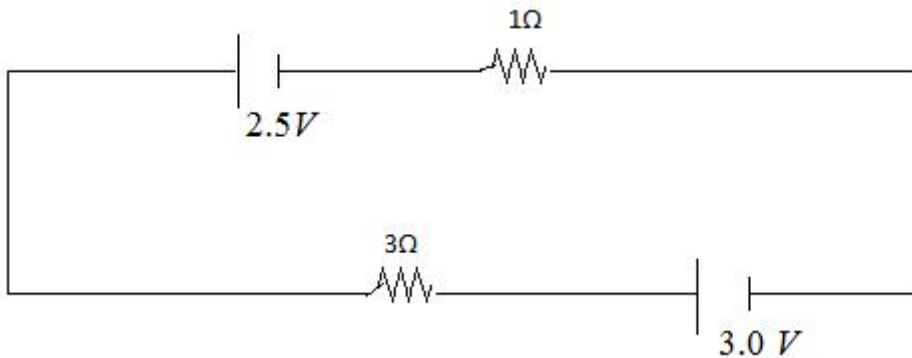

**Figure 1**

- (d) Other than magnetic field strength, state one factor that determines magnetic flux density. (1 marks)
- (e) Calculate the number of electrons contain in a body whose charge is  $q = -8.8 \times 10^{-17}\text{ C}$  (3 marks)
- (f) Determine the capacitance of a capacitor whose overlapping area is  $20\text{ cm}^2$  and that two plates are  $2\text{ cm}$  apart if the space between plates contain vacuum. (3 marks)
- (g) (i) Write down the expression for Ampere's law for the magnetic flux density  $\vec{B}$ . (1 mark)  
(ii) An ideal infinite solenoid has  $n$  turns per unit length and carries a current  $I$ . Show that the magnetic field inside the solenoid is given by  $\vec{B} = \mu_0 n I \hat{z}$  (5 marks)
- (h) Differentiate between resistivity and conductivity. (2 marks)

## Question TWO

Figure 2 shows a network of capacitors. Determine

- (i) The effective capacitance of the circuit (3 marks)  
(ii) The potential difference across capacitor  $C_1$  when fully charged. (3 marks)

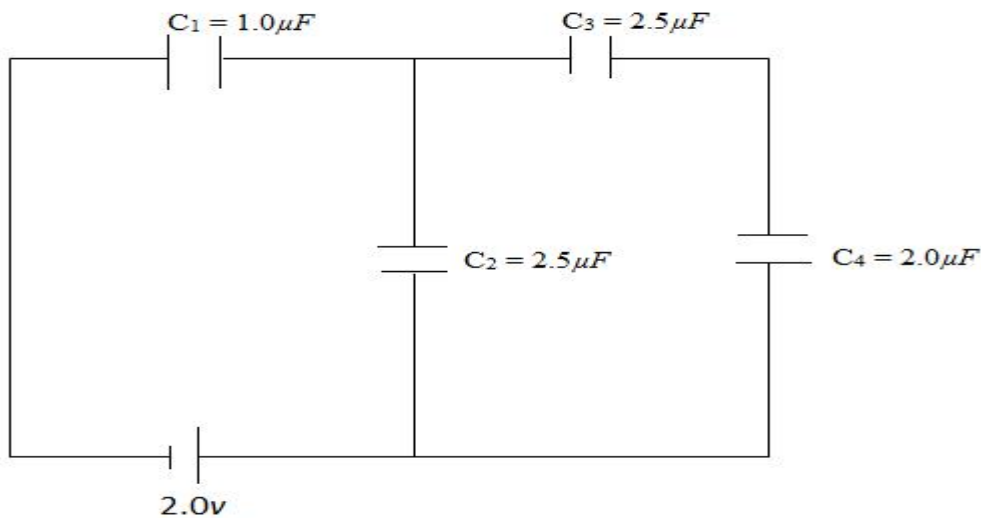

**Figure 2**

- (b) An electron that was initially moving at  $500ms^{-1}$  got into a region of uniform and perpendicular magnetic field of 0.5 tesla (T). Determine the radius of the part it followed (4 marks)
- (c) Determine the magnitude of the force experience by a current carrying conductor of length 0.8m carrying a current of magnitude 2.5A if it is perpendicular to a uniform magnetic field of 5 tesla. (3 marks)
- (d) (i) State the Ampere's law. (1 mark)  
(ii) Determine the magnetic field strength at appoint 10cm from a straight current carrying conductor which is carrying 10A. (3 marks)

### Question THREE

Two capacitors  $C_1 = 0.1-F$  and  $C_2 = 0.25-F$  are connected in series to a 12V battery.

- (i) Determine the charge and potential difference for each capacitor.  
(ii) The battery is now disconnected and the capacitor plates of like sign are connected. Calculate the final charge and potential difference for each capacitor. (4 marks)
- (b) The space between the plates of a parallel plate capacitor is filled with two dielectrics of equal size as shown in figure 3. The plates have area A and are d units apart. Determine the resulting capacitance. (5 marks)

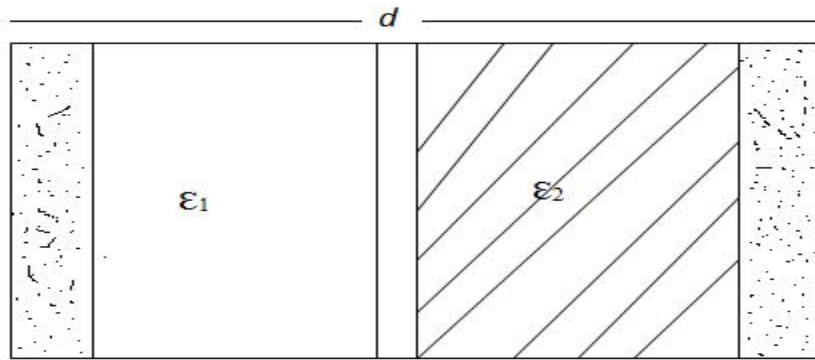

Figure 3

- (c) (i) Draw a circuit for a resistor, a capacitor and an emf source; all in series. (1 mark)
- (ii) When the circuit is closed, sketch a curve of
- I. Instantaneous charge stored in a capacitor versus time given that the capacitor

#### Question FOUR

Figure 4 shows three charges P, Q and R placed at 3m, 1m and 2m respectively from the origin, o. If  $P = 2.0 \times 10^{-16} \text{ C}$ ,  $Q = 1.0 \times 10^{-15} \text{ C}$  and  $R = 3.0 \times 10^{-16} \text{ C}$ , Determine:

- (i) The magnitude of the electric field at the origin o. (7 marks)
- (ii) The direction of the resultant electric field at o. (2 marks)
- (iii) The electric potential at o. (3 marks)

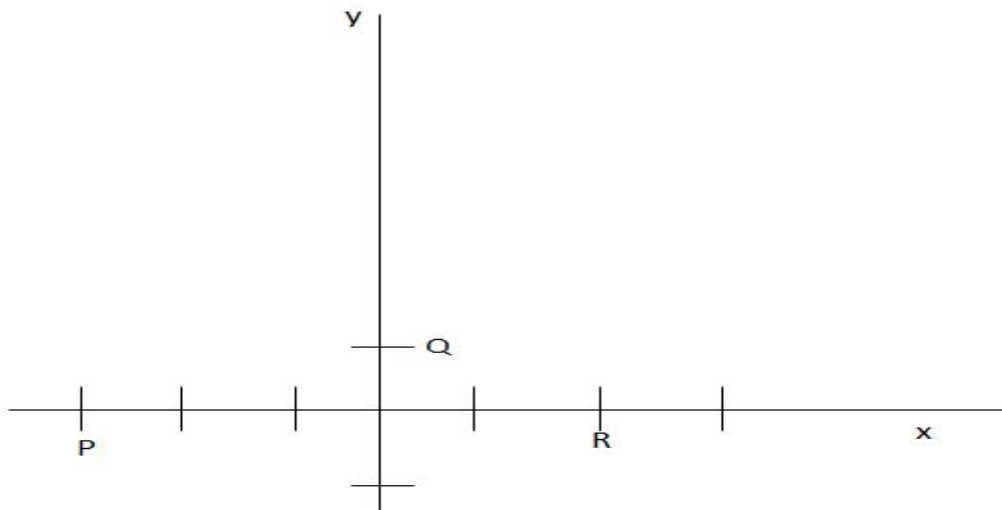
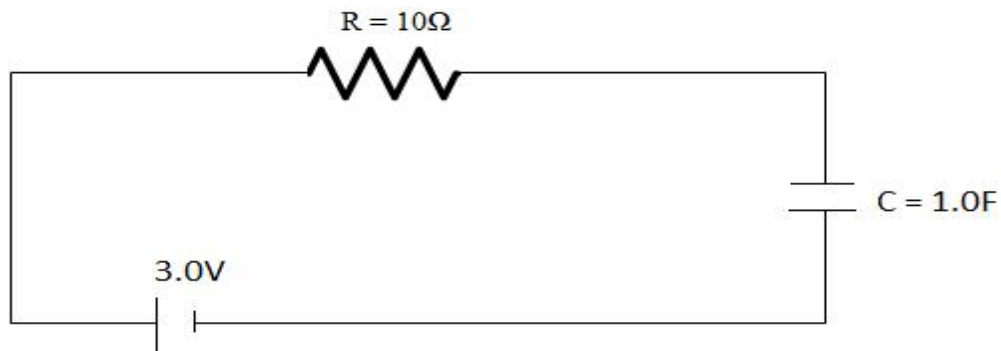

figure 4

(b) Figure 5 shows a simple circuit diagram used for charging a capacitor.



**FIGURE 5**

Explain using appropriate curves how:

- (i) The current flowing with circuit varies with time (1 mark)
- (ii) The p.d across R varies with time was initially uncharged (1 mark)
- (iii) Current versus time of the resultant circuit if after some time e.m.f was removed and the two ends connected to the e.m.f short circuited. (1 mark)
- (iv) State two factors that determine the charge stored in a charged capacitor.

